

# DGF7-14 Digital Ground Fault Protection reference manual



---

---

***Ground Fault Systems bv***

---

---

Ground Fault Systems B.V.  
Rijtersbleek-Aalten 4B15  
7521 RB Enschede  
The Netherlands

[www.groundfaultsystems.com](http://www.groundfaultsystems.com)  
[info@groundfaultsystems.com](mailto:info@groundfaultsystems.com)  
Tel: +31 53 4318628  
CofC: 55400914

<b>1. GENERAL DESCRIPTION</b>	<b>3</b>
<b>2. FUNCTIONALITY</b>	<b>4</b>
2.1 Dipswitch settings	4
2.1.1 Ground Fault Trip Current level – dipswitches 1, 2 & 3	4
2.1.2 Ground Fault Trip Delay Time – dipswitches 4, 5 & 6	4
2.1.3 Operating mode – dipswitches 7 & 8	5
2.2 LED indicators	6
2.3 Reset/Test pushbutton	6
2.4 External Current Sensor	6
2.5 Frame Bonding/Chassis Ground	7
2.6 Remote metering	7
<b>3. CONTROL VOLTAGE</b>	<b>8</b>
<b>4. CONNECTIONS AND PRECAUTIONS</b>	<b>9</b>
<b>5. CATALOGUE NUMBERS</b>	<b>11</b>
<b>6. TECHNICAL SPECIFICATIONS</b>	<b>12</b>
6.1 Ground fault circuit	12
6.2 Trip Time Accuracy	12
6.3 Remote metering	12
6.4 External button	12
6.5 Control Voltage	13
6.6 System power	13
6.7 Terminals	14
6.8 Relay contacts	14
6.9 Mechanical properties (installed)	15
6.10 Environment	15
<b>7. APPLICABLE STANDARDS</b>	<b>16</b>
<b>8. TABLES AND FIGURES</b>	<b>17</b>
8.1 Table 1 - Dipswitch settings	17
8.2 Table 2 - Primary current Trip level	18
8.3 Figure 1 - Typical NGR field connection using built-in Current Sensor	19
8.4 Figure 2 - Typical field connection with external Current Sensor	20
8.5 Figure 3 - Dimensions DGF7-14	21
8.6 Figure 4 - Reset/Test connection multiple DGF7-14s	21

## 1. GENERAL DESCRIPTION

The DGF7-14 is a microprocessor based ground fault unit for use on solidly grounded or resistance grounded systems. This innovative digital electronic unit measures ground fault current using a built-in 28 mm zero sequence Current Sensor (CS), or an external CS. With Control Voltage on, when the measured value reaches or exceeds the setting for current, during the delay time, the unit trips. External CSs with different cable windows, round or square and split core, and various current ratios are available.

The unit will react to alternating current (AC) only and will reject direct current (DC) signals. Accuracy will be maintained over a frequency range of 45 - 450 Hz, making it suitable for variable frequency drive applications. The DGF7-14 is a Class A device as defined in the IEC 60755 standard; it is therefore fully characterized for operation with sinusoidal AC and pulsating DC currents.

The DGF7-14 is designed for use with Neutral Grounding Resistors (NGR) having let-through current between 2 and 10 A.

The maximum system operating voltage for the DGF7-14 is 660 V, when passing the system power conductors through the built-in CS. However, by using any GFS external CS and insulating the busbars, or by using any suitably rated, commercially available, interposing CT and passing the secondary lead through the built-in CS, the unit can be used on any system voltage.

The DGF7-14 houses a non-isolated universal power supply from 24 - 240 V AC or DC and is equipped with form 'Z' (4 connections) isolated NO and NC contact sets to operate the upstream protection device and to indicate a failure of the system. The Ground Fault Current Trip level (1 – 10 A, 8 steps), Trip Delay Time (500 ms – 10 s, 8 steps) and the Relay Operating Mode (Continuous Non-Failsafe, Continuous Failsafe, Pulsed Auto Reset, Pulsed Non-Failsafe) are set on a front accessible dipswitch array.

A single press of an external, voltage free, momentary button resets the unit after a trip. A functional test of the DGF7-14 is started by double clicking the external button.

**WARNING:** invoking a test will and must trip the installation!

A green LED indicates four functions: slow flashes denote Control Voltage is present (1 s flashes); steady on after a test was invoked, during delay before test continuous flashes (0,25 s); two fast flashes per second denotes the unit has sensed a ground fault current higher than the Trip Level for a period longer than the Trip Delay Time and that the output contacts have operated (two 0,25 s flashes).

A 12 point Pull-apart terminal block simplifies connection of field wiring.

Terminals are provided for connection of an external voltmeter. The output is 0 to 10 V, proportional to the Trip Current Level set on the dipswitches.

The DGF7-14 is equipped with an aluminium profile enabling horizontal mounting on a DIN rail.

To ensure that the DGF7-14 will function in severe circumstances, it is encapsulated in polyurethane (PUR) to make sure it is not vulnerable to mechanical shock, vibration nor weather.

---

## 2. FUNCTIONALITY

### 2.1 Dipswitch settings

The DGF7-14 has dipswitches to set the desired Trip Current Level, Trip Delay time and Relay Operating Mode. Below is a summary of the different options. See [table 1](#) for the setting values.

#### 2.1.1 Ground Fault Trip Current level – dipswitches 1, 2 & 3

The DGF7-14 has eight fixed trip points between 1 and 10 A of primary fault current. The preferred trip point can be set with dipswitches 1 – 3. For values see [table 1](#). It is recommended that the Ground Fault Trip level is kept as close as possible to the charging current of the system the DGF7-14 is protecting. This will provide maximum safety for operating personnel and equipment.

On resistance grounded systems the Trip Current level should be set lower than 20% of the Neutral Grounding Resistor let-through current.

If the measured ground fault current exceeds the Trip Level setting, the unit will trip after the pre-selected Trip Delay.

#### 2.1.2 Ground Fault Trip Delay Time – dipswitches 4, 5 & 6

The G/F Trip Delay time can be between 500 ms and 10 s. [Table 1](#) provides settings for dipswitches 4, 5 & 6.

Set the G/F Trip Delay time to provide the desired delay before the output relay changes state when the G/F Trip Level is reached or exceeded.

The setting should be selected to co-ordinate with other ground-fault devices connected on the same power transformer secondary: set shorter than upstream devices; set longer than downstream devices. If no other ground-fault devices are connected, set for the shortest possible time.

### 2.1.3 Operating mode – dipswitches 7 & 8

The DGF7-14 user can select one of four distinct Operating Modes for the device. All modes have in common:

- In the 'reset state' of the relay the NO<sup>1</sup> contact is open and the NC<sup>1</sup> contact is closed.
- In the 'tripped state' of the relay the NO contact is closed and the NC contact is open.

See [Table 1](#) for the corresponding dipswitch settings.

The different modes are listed below:

1. Continuous Non-Failsafe, power-down-reset operation (used for Under Voltage devices)  
If during normal operation Control Voltage is removed, the output relay does not change state. When Control Voltage is restored, the relay remains untripped. If Control Voltage is removed the unit will go to the reset state unconditionally. If the fault is still present when Control Voltage is restored, the unit will trip after its power-up time.
2. Continuous Failsafe, power-on-reset operation (used for Under Voltage devices)  
If during normal operation Control Voltage is removed the relay goes to the tripped state unconditionally. When Control Voltage is restored and there is no fault present, the unit will reset after its power-up time. If there is a fault present when Control Voltage is removed or restored the unit stays tripped.
3. Auto Reset, Non-Failsafe operation (used for shunt controlled breakers)  
If during normal operation Control Voltage is removed, the output relay does not change state. When Control Voltage is restored, the relay remains untripped. If the unit is tripped when Control Voltage is removed, the output relay will reset after a short delay. If the fault is still present when Control Voltage is restored, the unit will trip after its power-up time.  
The unit resets under one of the following conditions:
  - Three seconds after the fault current falls below Trip Level.
  - After a short delay after Control Voltage is removed.
  - Three second after a test has been performed.
 Note: if wired as seen in figure 1 this operating mode is used as pulsed trip for the breaker. The pulsed trip prevents damage to the internal mechanism of the circuit breaker in the event that the operator tries to reset the circuit breaker while the trip contact is still closed.
4. Pulsed Non-Failsafe operation (used for shunt controlled breakers)  
When a trip occurs, the relay goes to the tripped state for 0,5 s, and then reverts back. Should the measured current remain above the set G/F trip level, then this pulse is repeated every 3 s. The green LED will show two flashes until the unit is reset. The LED remains active (until the reset button is pressed or there is no fault present when Control Voltage is removed) enabling the user to verify which DGF7-14 tripped its associated breaker. If one forgets to reset the unit, then the functionality of the trip circuit is not impaired; in other words, in case of a trip condition the relay will correctly issue a pulse, even if the LED is active.  
When Control Voltage is removed the relay will not issue a pulse.

Application information:

- The Continuous Failsafe and Non-Failsafe modes can be used when the output relay is operating undervoltage devices. This includes: contactor coils, starter coils and circuit breakers equipped with Under Voltage Release (UVR) trip coils. In Failsafe mode the Control Voltage of the unit must not be interrupted by the action of the Under Voltage (UV) trip.
- The Pulsed Auto Reset and Non-Failsafe modes are designed for applications where the output relay is operating a shunt trip device. The output contact to the shunt trip coil opens after a successful trip, to prevent damage to the internal mechanism of the circuit breaker in the event that the operator tries to reset the circuit breaker while the trip contact is still closed.

The green LED shows operating state (power on, trip or test). See [section 2.2](#) for LED indicators.

<sup>1</sup> (NO = Normally Open, NC = Normally Closed)

If the DGF7-14 is to be used for alarm only purposes (rather than to interrupt ongoing processes), and the alarm has to have an auto-resetting nature, then one has to resort to one of the Pulsed modes. The pulses will be repeated as long as current is above the set G/F level.

## 2.2 LED indicators

The unit has a green 'RUN' LED showing correct operation by slowly flashing (1 s flashes). When the unit has tripped, the LED will show two 0,25 s flashes. After a test had been invoked the LED will turn on solidly (during the delay time the LED will show continuous 0,25 s flashes).

## 2.3 Reset/Test pushbutton

A normally open momentary button, can be connected to the DGF7-14 on terminals R1 and R2, and is used to reset the internal relay and the LED. The remote button must be a voltage-free contact; no external power supply is required. See section 6.3.

A reset will only be granted if the cause of the trip is cleared. Otherwise, the relay will remain activated without glitches.

With the unit in Auto Reset, the relay and LED electronics reset automatically in 3 seconds. The reset button does not have to be pressed.

With the unit in the Pulsed Non-Failsafe mode, the relay pulses for 0,5 seconds. If Control Voltage is maintained on the relay after a ground fault and the ground fault has been cleared, it is necessary to press the reset button to reset the LED electronics.

Double-clicking the button invokes a test which switches an AC test-voltage onto the built-in processor's CS input. The voltage is scaled to simulate a residual current of 1,2 times the G/F trip level. The unit will trip on G/F after the set delay (plus 0,4 s) and then switch off the AC test-voltage. The green LED turns on solidly. While waiting for the delay time to pass, after a test request, the green LED will show continuous 0,25 s flashes.

The reset button needs to be pressed again to reset the unit.

**WARNING:** invoking a test will and must trip the installation!

## 2.4 External Current Sensor

Each CS series sensor is epoxy moulded for exceptional mechanical properties and has a high-grade silicon iron core for excellent coupling characteristics under all temperature situations. All CS series current sensors are protected against emitting high voltages when the secondary output is not properly connected. The maximum voltage is 25 V RMS.

Refer to [Figure 2](#) for correctly connecting the CS. Pass the phase conductors through the CS window. If the neutral conductor is being connected downstream, it is to be passed through the window. Do not pass ground conductors through the CS window. In applications that require shielded wires to pass through the CS window, return the shields through the CS window before connecting them to ground.

Position power cables in the centre of the current sensor's window. Keep cables and buswork clear of the split on split core current sensors.

See [section 5](#) for the available Current Sensors.

## 2.5 Frame Bonding/Chassis Ground

For optimum EMC performance and safety, the FB (Frame Bond) terminal must be firmly connected to the local frame or chassis ground. The chassis ground must not be more than 50 mm away from the unit.

If the DGF7-14 is mounted on a 35 mm DIN rail, a 'DIN rail ground terminal block' can be installed beside the unit to act as the chassis ground point. Use a 2 - 2,5 mm<sup>2</sup> (14 AWG) stranded conductor.

[Back to Connections and Precautions.](#)

## 2.6 Remote metering

Terminal blocks are provided for connection of an external voltmeter. The output is 0 to 10 V, proportional to the Trip Current Level set on the dipswitches. For example: if the trip current level is set at 4 A, the 0 – 10 V would be proportional to 0 – 4 A.

Terminals M+ and M- are not isolated from the Control Voltage; terminal M- is internally connected to FB.

### 3. CONTROL VOLTAGE

The DGF7-14 has a universal power supply input, accepting nominal voltages between 24 and 240 V AC or DC with a -20% / +10% tolerance. The total range of accepted voltages is therefore 19,2 to 264 V AC or DC. Power consumption is a mere 1,2 VA maximum with AC voltages and 0,5 W maximum with DC voltages.

Note that the built-in power supply circuit is non-isolated. There is no electrical isolation between the Control Voltage input and the internal electronics, which therefore share a common ground reference. This reference is applied to the system through the FB (Frame Bond) terminal which must be firmly connected to local frame or chassis ground with a maximum of 50 mm distance from the unit for safety and proper EMC behaviour. Use a 2 - 2,5 mm<sup>2</sup> (14 AWG) stranded conductor. Control Voltage is subsequently presented to the L+ terminal with respect to chassis ground. AC voltage sources connect their 'cold' FB side to the chassis and distribute their 'hot' L side through wiring to the L+ terminals. DC voltage sources connect their 'cold' – side to the chassis and distribute their 'hot' + side through wiring to the L+ terminal. For good EMC behaviour it is important (as in any installation) to run all wiring close along the chassis or in metal ducts, avoiding excess lengths and coiled up wires.

## 4. CONNECTIONS AND PRECAUTIONS

Please consult the following checklist when installing the DGF7-14.

1. Please review [Figure 1, 2 and 3](#) for typical field connections.
2. If the DGF7-14 is used for alarming only purposes, or if the G/F Trip Delay Time is set to 1 s or higher, verify that the DGF7-14 cannot be subjected to conditions exceeding its Thermal Withstand Capability (see [section 6.1](#)).
3. Place the DGF7-14 in a clean dry enclosure. Locate the relay in the vicinity of the isolating device (circuit breaker or contactor) that is protecting the circuit being monitored.
4. Provide maximum clearance between the DGF7-14 (plus the external CS, if used) and any strong magnetic flux producing devices such as power transformers, autotransformers, control transformers, reactors, high power conductors, contactors and other buswork.
5. Lead the power conductors of the circuit being monitored (including Neutral if any and excluding the ground wire) through the internal OR external CS's window. WARNING: Never lead conductors through both the internal and the external CS at the same time.
6. All connections to the DGF7-14 are by means of screw clamp pull-apart terminals rated 10 A, 300 V. Terminals will accept 0,14 – 4,0 mm<sup>2</sup>, 26 - 12 AWG solid or stranded conductors. The user may want to identify the following terminals:
  - M+ and M- for connecting a remote voltmeter.
  - T1 and T2 for connecting an external CS, use 2 - 2,5 mm<sup>2</sup>, 14 AWG stranded wire.
  - R1 for connecting an external momentary, NO, voltage free, pushbutton
  - R2 common for external pushbutton
  - FB for providing an absolute ground reference to the system (refer to [section 2.5](#)), use 2 - 2,5 mm<sup>2</sup>, 14 AWG stranded wire.
  - L+ for connecting AC or DC Control Voltage's 'hot' side.
  - 11 and 12 for connecting the normally closed (NC) contact of the relay.
  - 13 and 14 for connecting the normally open (NO) contact of the relay.
7. See National Electrical Code for minimum required wire gauges.
8. In order to meet the Electromagnetic Compatibility (EMC) requirements a firm and short connection is required between terminal FB and the chassis ground point. The chassis ground must not be more than 50 mm away from the unit.
9. If the DGF7-14 is mounted on a 35 mm DIN rail, a 'DIN rail ground terminal block' can be installed beside the unit to act as the chassis ground point. Use a 2 - 2,5 mm<sup>2</sup> (14 AWG) stranded conductor.
10. For good EMC behaviour it is important (as in any installation) to run all wiring, especially if unshielded, close along the chassis or in metal ducts, avoiding excess lengths and coiled up wires.
11. Integrate the relay contacts into the projected control circuit. Apply appropriate fusing to protect the contacts (13 A maximum).
12. If an external CS is being used, connect the two secondary terminals of the CS to terminals T1 and T2 of the DGF7-14 using 2 – 2,5 mm<sup>2</sup> (14 AWG) shielded twisted pair cable. Connect the shield to chassis ground by means of a clamp, close to the DGF7-14 (where the FB terminal is bonded to chassis ground as well). From the clamp to terminals T1 and T2 the wires can be left unshielded. Please note that terminal T1 is internally connected to terminal FB of the DGF7-14. Since terminal FB must be grounded, it means that the external CS will be grounded automatically. If separate grounding is required by electrical regulations, the external CS terminal connected to T1 should be connected to the same grounding point as terminal FB of the DGF7-14. This will avoid ground loops and nuisance tripping.
13. Up to six DGF7-14 units in the same enclosure may share a common remote Reset/Test button. Connect one terminal of the button to terminal R1 of one of the units, and connect the other terminal of the button to terminals R2 of all the units in parallel.
14. Position power cables in the centre of the current sensor window. Keep cables and buswork clear of the split on split core Current Sensors.

15. Verify that the polarity of the conductors is correct when they pass through the CS. Verify that ground paths do not run through the CS, except when applications require shielded wires to pass through the CS window, in that case return the shields through the CS window before connecting them to ground.
16. Phase Conductors must be insulated for the system voltage when it is higher than 660 V.
17. Secure the unit horizontally to the DIN rail.
18. Connect the external reset button to terminals R1 and R2 of the DGF7-14 using twisted pair cable (of any gauge accepted by the terminals). If the distance between the button and the DGF7-14 exceeds 1 m, shielded cable is recommended, the shield being connected to chassis ground by means of a clamp, close to the DGF7-14 (where the FB terminal is bonded to chassis ground as well). From the clamp to the terminals the wires can be left unshielded.  
NOTE: Terminals R1 and R2 are NOT isolated. Terminal R2 is internally connected to terminal FB. The external reset button must be a voltage-free NO contact; no external power supply is required. See [section 6.4](#).
19. Refer to [figure 1](#). Pass the neutral conductor running from the star point of the transformer secondary to the Neutral Grounding Resistor (NGR) through the CS window. Note that the relay is located on the ungrounded side of the NGR. This is the preferred location so that any ground ahead of the NGR but after the DGF7-14 will be detected.
20. The DGF7-14 Trip Level range is 1 A to 10,0 A when using the built-in CS. The maximum continuous primary phase current is to be 100 A.
21. Terminals M+ and M- are not isolated from the Control Voltage; terminal M- is internally connected to FB.

NOTE: Use the correct type of CS as specified in [section 5](#). The use of standard type of core balance current transformers, connected to the external CS input, may lead to catastrophic failure of the DGF7-14.

## 5. CATALOGUE NUMBERS

DGF7-14	Ground Fault Protection Unit with built-in 28 mm CS, 24 – 240 V AC or DC Control Voltage, for use on 660 V maximum, 45 - 450 Hz power systems. Optional: external CS, remote Reset/Test button and/or remote voltmeter.
CS5-028	Zero sequence current sensor, 28 mm window, 500:1 ratio
CS5-050	Zero sequence current sensor, 50 mm window, 500:1 ratio
CS5-065	Zero sequence current sensor, 65 mm window, 500:1 ratio
CS5-090	Zero sequence current sensor, 90 mm window, 500:1 ratio
CS5-150	Zero sequence current sensor, 150 mm window, 500:1 ratio
CS5-240	Zero sequence current sensor, 240 mm window, 500:1 ratio
CS5-1517	Zero sequence current sensor, 150 x 170 mm window, 500:1 ratio *
CS5-1025	Zero sequence current sensor, 100 x 250 mm window, 500:1 ratio *
CS5-1035	Zero sequence current sensor, 100 x 350 mm window, 500:1 ratio *
CS5-2028	Zero sequence current sensor, 200 x 280 mm window, 500:1 ratio
CS5-3030	Zero sequence current sensor, 300 x 300 mm window, 500:1 ratio *
CS10-095	Zero sequence current sensor, 95 mm window, 1000:1 ratio
CS10-144	Zero sequence current sensor, 144 mm window, 1000:1 ratio
CS10-240	Zero sequence current sensor, 240 mm window, 1000:1 ratio
CS10-1025	Zero sequence current sensor, 100 x 250 mm window, 1000:1 ratio *
CS10-1035	Zero sequence current sensor, 100 x 350 mm window, 1000:1 ratio *
CS10-2028	Zero sequence current sensor, 200 x 280 mm window, 1000:1 ratio
CS20-095	Zero sequence current sensor, 95 mm window, 2000:1 ratio
CS20-144	Zero sequence current sensor, 144 mm window, 2000:1 ratio
CS20-240	Zero sequence current sensor, 240 mm window, 2000:1 ratio
CS20-1025	Zero sequence current sensor, 100 x 250 mm window, 2000:1 ratio *
CS20-1035	Zero sequence current sensor, 100 x 350 mm window, 2000:1 ratio *
CS20-2028	Zero sequence current sensor, 200 x 280 mm window, 2000:1 ratio
CS100-095	Zero sequence current sensor, 95 mm window, 10.000:1 ratio
CS100-144	Zero sequence current sensor, 144 mm window, 10.000:1 ratio
CS100-240	Zero sequence current sensor, 240 mm window, 10.000:1 ratio
CS100-2028	Zero sequence current sensor, 200 x 280 mm window, 10.000:1 ratio

\* These current sensors are also available as a split core version, which adds /S to the name, e.g. when ordered the name is CS5-1517/S.

Note 1: all the CS5, CS10, CS20 and CS100 type Current Sensors are for use with Ground Fault Systems devices only.

Note 2: all Ground Fault Systems devices can only be used with CS series sensors, except for interposing CTs with their secondary wiring through the internal CS of the DGF7-14.

Note 3: all CS series current sensors are protected against emitting high voltages when the secondary output is open circuit. The maximum voltage is 25 V RMS.

[Back to External Current Sensor.](#)   [Back to Connections and precautions.](#)   [Back to 6.1.](#)

## 6. TECHNICAL SPECIFICATIONS

### 6.1 Ground fault circuit

G/F Trip Level (settable)	1 – 1,5 – 2,0 – 2,5 – 4,0 – 6,0 – 8,0 – 10,0 A			
Accuracy of G/F trip point	-15% / +0% of Trip Level <sup>1</sup>			
G/F Trip Delay Time (settable)	0,5 - 1,0 – 1,5 – 2,0 – 2,5 – 5,0 – 7,5 – 10,0 s			
Accuracy of G/F Trip Delay Time	-2 / +5 ms or $\pm 2,5\%$ of Trip Delay Time, whichever is greater at > 10 times setting. See also <a href="#">section 6.2</a> .			
Thermal withstand capability	300 A	infinitely	1500 A	500 ms
	500 A	2000 ms	$\geq 2000$ A	300 ms
	1000 A	700 ms		
Thermal withstand capability with external CS Ratio 500:1	300 A	infinitely	2000 A	125 ms
	500 A	2000 ms	5000 A	20 ms
	1000 A	500 ms		
Thermal withstand capability with external CS Ratio 10.000:1	10.000 A	3,00 s		
	50.000 A	1,00 s		
	200.000 A	0,05 s		
Suitable external Current Sensor types	Different sizes with 500:1, 1000:1, 2000:1 and 10.000:1 ratio, including split rectangular sensors. See <a href="#">section 5</a> .			

<sup>1</sup> The accuracy of the trip point refers to the value of the real world leakage current (assuming a purely sinusoidal wave shape) that just causes a trip when slowly increased from zero.

[Back to Connections and precautions.](#)

### 6.2 Trip Time Accuracy

The ground fault detection mechanism has a 'thermal' behaviour for greatly reduced noise sensitivity: the quoted delays are valid for sinusoidal currents exceeding the setpoint by >10 times. For reduced current excursions the delay increases as follows:

Trip current settings exceeded by a factor of:	1,2	2	4	>6
Increased Delay by:	60 ms	20 ms	8 ms	3 ms

For IEC 60755 'pulsating DC' currents, the delay increases by a further 50 ms maximum.

### 6.3 Remote metering

Accuracy (% FS)	2.5 %
Minimum load resistance	5 k $\Omega$

### 6.4 External button

Type of button	Single pole, voltage free, normally open, momentary.
Voltage across / current through contact	5 V DC, 1 mA

Maximum number of units that can be controlled in parallel from one voltage-free button	6, all in the same enclosure.
Maximum total length of datalink	Max. 5 m, within one enclosure. Use shielded cable for over 1 m.

[Back to Connections and precautions.](#)

## 6.5 Control Voltage

Voltage range	Nominal: 24 – 240 V AC/DC
Operating voltage tolerance:	80% to 110% of rated AC/DC voltage Total range: 19,2 - 264 V AC/DC
Frequency range on AC voltages	45 – 450 Hz
Power consumption	1,2 VA @ AC, 0,5 W @ DC
Isolation voltage	Not electrically isolated from electronics
Loss of supply tolerance (no impaired operation)	250 ms @ 24 V AC 1 s @120 V AC 4 s @230 V AC 80 ms @ 24 V DC 350 ms @ 48 V DC 750 ms @110 V DC
Power-up time	Max 500 ms for G/F detection <sup>1</sup>

<sup>1</sup> If a ground fault causing a residual current above the G/F Trip Current Level, is already present when Control Voltage is applied, the system trips just as soon as possible, irrespective of the G/F Trip Delay time setting (rationale: the fault may be present much longer than the delay set).

## 6.6 System power

Voltage and current range (internal CS)	0 – 660 V AC, 0 – 100 A
Voltage and current range (external CS)	Any, providing the power conductors are insulated for the system voltage.
Frequency range	45 - 450 Hz
Isolation voltage (internal CS)	2,5 kV RMS, 1 minute

**6.7 Terminals**

Type	Pull-apart
c-UL-us rating	300 V AC, 10 A
VDE rating	250 V AC, 12 A, pollution degree 3, over-voltage category III
Insulation stripping length	7 mm
Torque	0,4 – 0,6 Nm
Field wiring <i>See National Electrical Code for minimum required wire gauges.</i>	0,14 – 4,0 mm <sup>2</sup> (VDE) 26 - 12 AWG (UL), Cu or Al, solid or stranded

**6.8 Relay contacts**

Configuration	Voltage free, 1 NO and 1 NC contact, 4 terminals
c-UL-us rating	5 A @ 250 V AC, general use 5 A @ 30 V DC, resistive 1/6 hp, 250 V AC 2 A, 250 VA, @ 125 V AC, pilot duty 1 A, 250 VA, @ 250 V AC, pilot duty 0,88 A, 26,4 VA, @ 30 V DC, pilot duty <u>B300:</u> 30 A, 3600 VA make, 3 A 360 VA break @ 120 V AC  15 A, 3600 VA make, 1,5 A 360 VA break @ 240 V AC
EN 60947 rating	5 A @ 250 V AC utilization category AC-12 4 A @ 250 V AC utilization category AC-13 3 A @ 250 V AC utilization category AC-14 3 A @ 250 V AC utilization category AC-15 5 A @ 30 V DC utilization category DC-12 3 A @ 24 V DC utilization category DC-13 Maximum fuse rating 13 A (EN 60947-5-1)
Isolation voltage between contacts and coil	3 kV RMS, 50 – 60 Hz, 1 minute
Breakdown voltage between open contacts	1 kV RMS, 50 – 60 Hz, 1 minute
Between contact sets	2 kV RMS, 50 - 60 Hz, 1 minute

## 6.9 Mechanical properties (installed)

See [figure 3](#).

Height	45 mm
Width	70 mm
Depth (not including terminal block)	91 mm
Depth (including terminal block)	113 mm
Depth (including terminal block and bracket)	121 mm
Internal CS window diameter	28 mm
DIN rail if DIN rail mounted	35 mm
Screws if screw mounted	M5 x 20 (2 needed)
Weight (open)	0,40 kg
Weight (packaged)	0,50 kg

## 6.10 Environment

Operating temperature	-35 °C to +60 °C
Storage temperature	-40 °C to +80 °C
Humidity	85% max (no condensation)
Ingress protection	IP20
Mechanical shock resistance (no malfunction)	10 G
Vibration resistance (no malfunction)	10 G, 10 – 55 Hz at 1,5 mm double amplitude

The DGF7-14 is encapsulated in polyurethane (PUR) to keep the exposure to mechanical shock, vibration and weather to a minimum.

## 7. APPLICABLE STANDARDS

EN 61000-6-3	Electromagnetic compatibility (EMC) – Part 6-3: Generic standards – Emission standard for residential (=lowest levels). 30- 230 MHz 30 dB $\mu$ V at 10 m distance 230-1000 MHz 37 dB $\mu$ V at 10 m distance
EN 61000-6-4	Electromagnetic compatibility (EMC) Part 6-4: Generic standards - Emission standard for industrial environments.
EN 61000-6-8	Electromagnetic compatibility (EMC) – Part 6-8: Generic standards – Emission standard for professional equipment in commercial and light-industrial locations.
EN 61000-6-2	Electromagnetic compatibility (EMC) – Part 6-2: Generic standards – Immunity standard for industrial environments (=highest levels) 80-1000 MHz with 80% AM modulation up to 10 V/m at 3 m distance from source.
EN 61000-4-2	Electromagnetic compatibility (EMC) - Part 4-2: Testing and measurement techniques - Electrostatic discharge immunity test.
EN 61000-4-3	Electromagnetic compatibility (EMC) - Part 4-3: Testing and measurement techniques - Radiated, radio-frequency, electromagnetic field immunity test.
EN 61000-4-4	Electromagnetic compatibility (EMC) Part 4-4: Testing and measurement techniques - Electrical fast transient/burst immunity test.
EN 61000-4-5	Electromagnetic compatibility (EMC) Part 4-5: Testing and measurement techniques - Surge immunity test.
EN 61000-4-6	Electromagnetic compatibility (EMC) Part 4-6: Testing and measurement techniques - Immunity to conducted disturbances, induced by radio-frequency fields.
EN 61000-4-11	Electromagnetic compatibility (EMC) Part 4-11: Testing and measurement techniques - Voltage dips, short interruptions and voltage variations immunity tests for equipment with input current up to 16 A per phase.
EN 60947-5-1	Low-voltage switchgear and controlgear – Part 5-1: Control circuit devices and switching elements – Electromechanical control circuit devices.
IEC 60755	General requirements for residual current operated protective devices
c-UL-us	<a href="#">UL 1053 UL standard for Safety Ground-Fault Sensing and Relaying Equipment, Class 1.</a> <a href="#">CSA C22.2 NO. 144-M1991 CSA standard for Ground Fault Circuit Interrupters.</a>  <a href="#">File E203514</a>
CE	CE mark – Declaration of Conformity

## 8. TABLES AND FIGURES

### 8.1 Table 1 - Dipswitch settings

'D' denotes down and 'U' denotes up.

Values are primary currents for a 500:1 ratio internal or external Current Sensor. For other ratio's see [Table 2](#).

Switch no.	Parameter	Set to	Meaning
1 2 3	Ground Fault Trip level	D U U D U D D D U D D D ♦ U U U U U D U D U U D D	1,0 A 1,5 A 2,0 A 2,5 A 4,0 A 6,0 A 8,0 A 10,0 A
4 5 6	Ground Fault Trip Delay time and Trip Inhibit	D D D ♦ D D U D U D D U U U D D U D U U U D U U U	500 ms 1,0 s 1,5 s 2,0 s 2,5 s 5,0 s 7,5 s 10,0 s
7 8	Operating Mode	D D ♦ D U U D U U	Continuous Non-Failsafe operation Continuous Failsafe operation Pulsed Auto Reset operation Pulsed Non-Failsafe operation
♦ Factory settings			

[Back to Dipswitch settings.](#)

[Back to Operating Modes.](#)

## 8.2 Table 2 - Primary current Trip level

Values are primary currents.

DGF7-14 Setting	External current sensor ratio's				Interposing CT ratio's	
	500:1	1000:1	2000:1	10.000:1	500:5	5000:5
1,0 A	1,0 A	2,0 A	4,0 A	20,0 A	100 A	1,0 kA
1,5 A	1,5 A	3,0 A	6,0 A	30,0 A	150 A	1,5 kA
2,0 A	2,0 A	4,0 A	8,0 A	40,0 A	200 A	2,0 kA
2,5 A	2,5 A	5,0 A	10,0 A	50,0 A	250 A	2,5 kA
4,0 A	4,0 A	8,0 A	16,0 A	80,0 A	400 A	4,0 kA
6,0 A	6,0 A	12,0 A	24,0 A	120 A	600 A	6,0 kA
8,0 A	8,0 A	16,0 A	32,0 A	160 A	800 A	8,0 kA
10,0 A	10,0 A	20,0 A	40,0 A	200 A	1000 A	10,0 kA

[Back to Table 1.](#)

8.3 Figure 1 - Typical NGR field connection using built-in Current Sensor

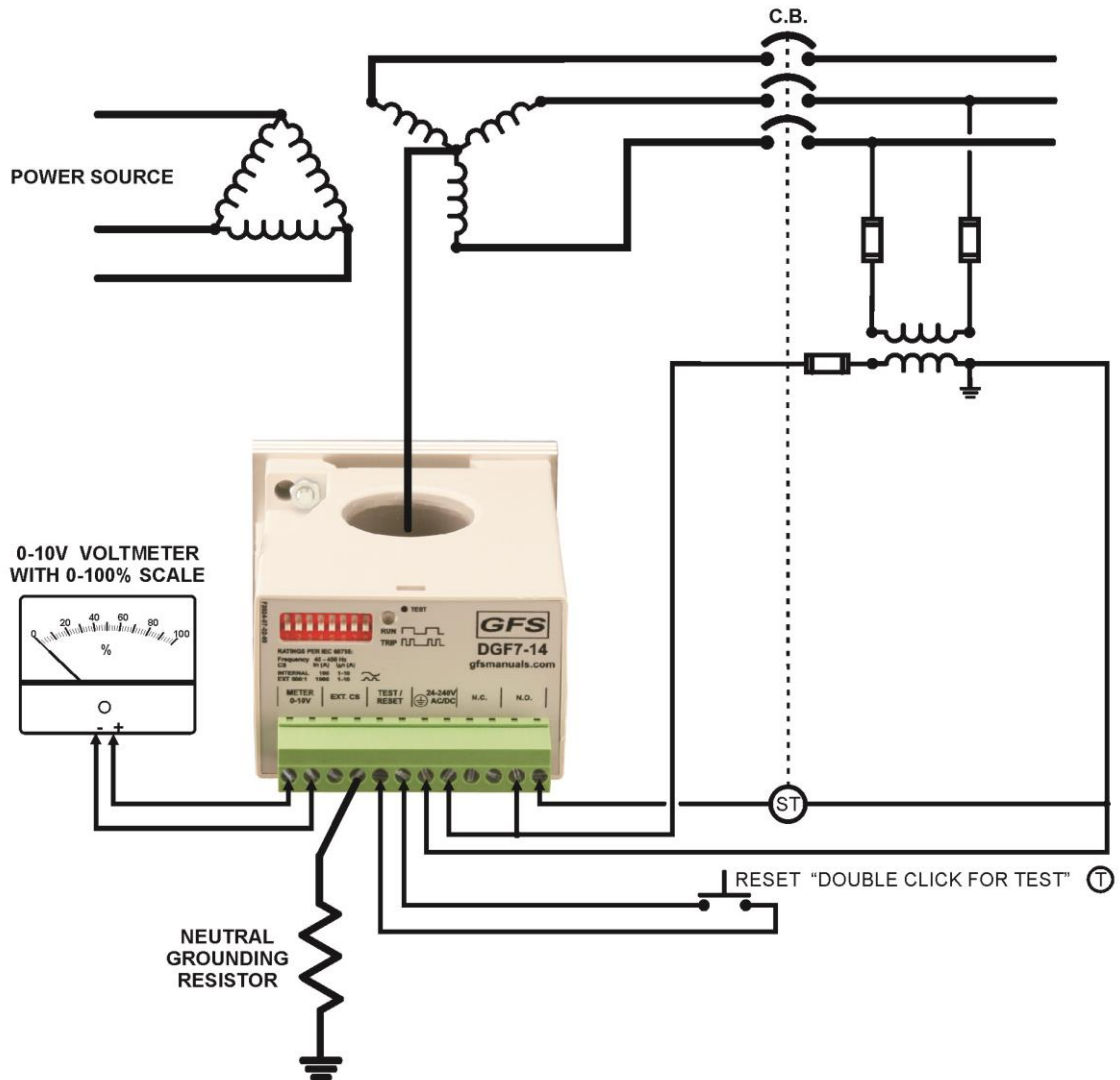

8.4 Figure 2 - Typical field connection with external Current Sensor

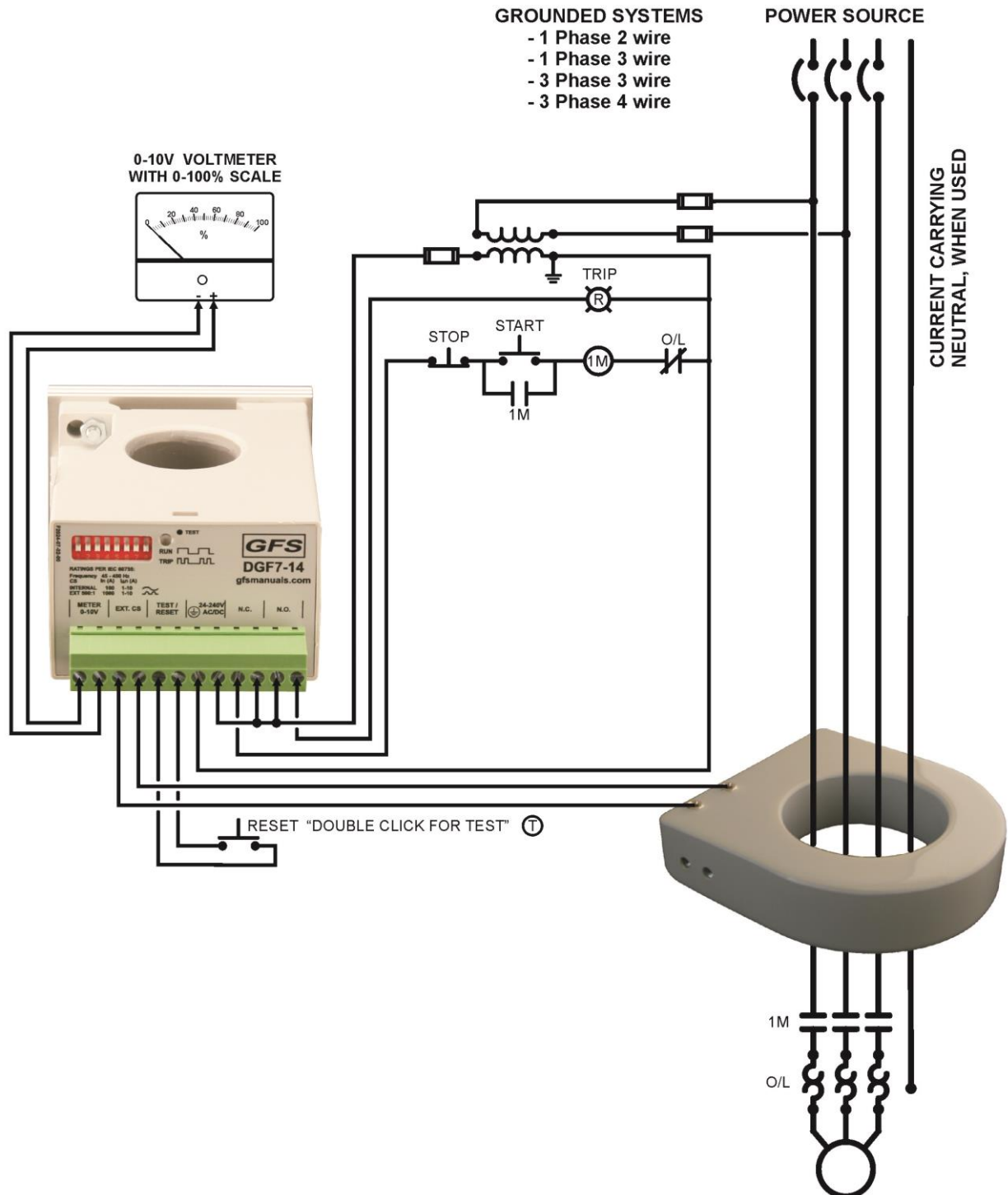

8.5 Figure 3 - Dimensions DGF7-14

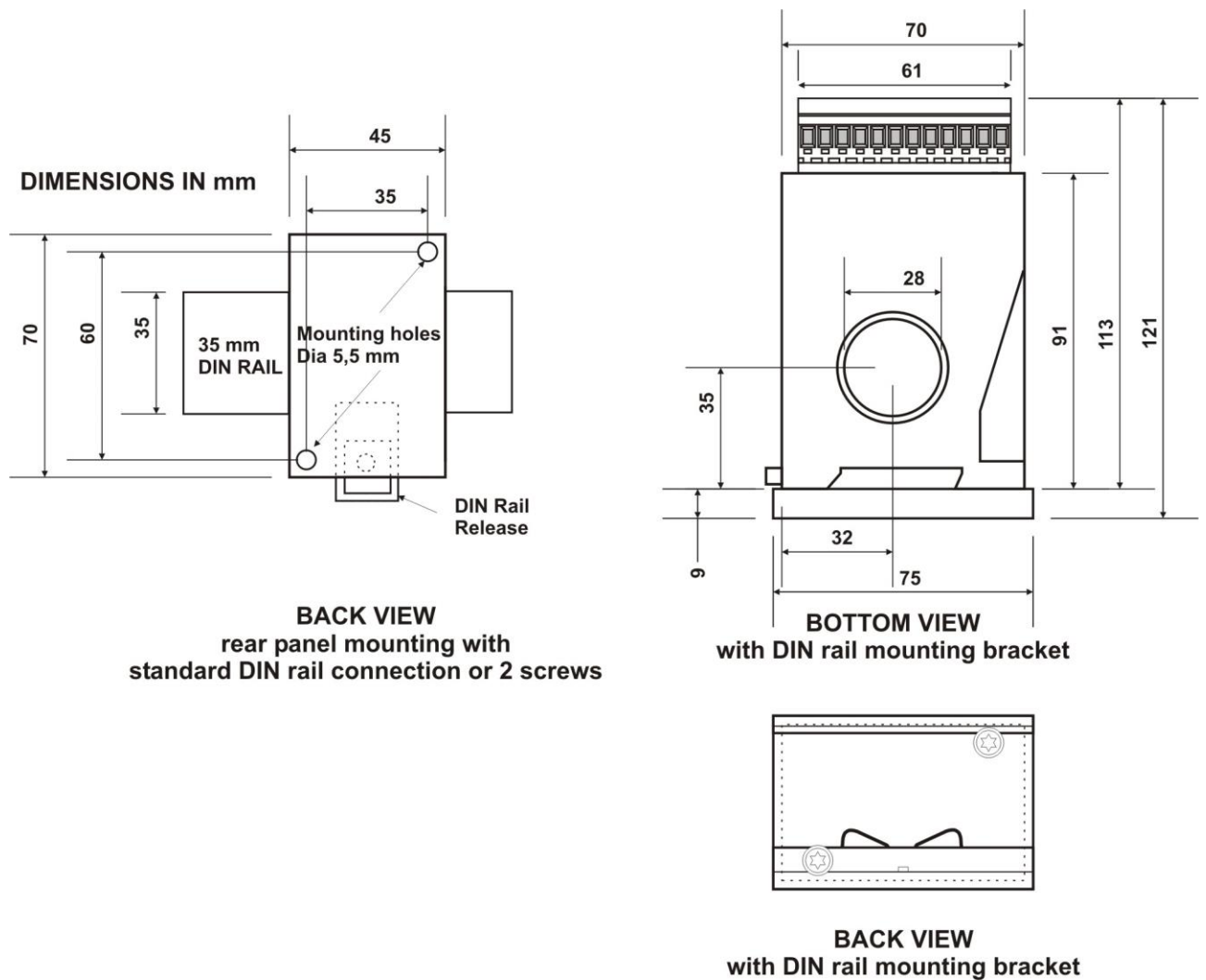

8.6 Figure 4 - Reset/Test connection multiple DGF7-14s

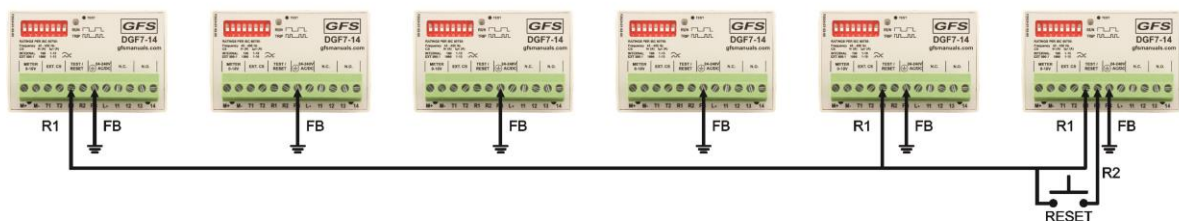

Connection of up to six DGF7-14s in the same enclosure with one Reset/Test button