

DGF7-18 Digital Ground Fault Protection reference manual



Ground Fault Systems bv

Ground Fault Systems B.V.
Rijtersbleek-Aalten 4B15
7521 RB Enschede
The Netherlands

www.groundfaultsystems.com
info@groundfaultsystems.com
Tel: +31 53 4318628
CofC: 55400914

1. GENERAL DESCRIPTION	3
2. FUNCTIONALITY	4
2.1 Dipswitch settings	4
2.1.1 Ground Fault Trip Current level – dipswitches 1, 2 & 3	4
2.1.2 Ground Fault Trip Delay Time – dipswitch 4	4
2.2 Operating modes	5
2.3 LED indicators	5
2.4 Test/Reset pushbutton	5
2.5 External Current Sensor	6
2.6 Frame Bonding/Chassis Ground	6
3. CONTROL VOLTAGE	7
4. CONNECTIONS AND PRECAUTIONS	8
5. CATALOGUE NUMBERS	10
6. TECHNICAL SPECIFICATIONS	11
6.1 Ground fault circuit	11
6.2 Trip Time Accuracy	11
6.3 External button	11
6.4 Control Voltage	12
6.5 System power	12
6.6 Terminals	12
6.7 Relay contacts	13
6.8 Mechanical properties (installed)	13
6.9 Environment	14
7. APPLICABLE STANDARDS	15
8. TABLES AND FIGURES	16
8.1 Table 1 - Dipswitch settings	16
8.2 Table 2 - Primary current Trip level	16
8.3 Figure 1 - Typical Field Connection using built-in CS, contactor and Test/Reset (NO)	17
8.4 Figure 2 - Typical field connection with external CS, shunt trip and Test/Reset (NC)	18
8.5 Figure 3 - Typical field connection with interposing CT, shunt trip and Test/Reset (NC)	19
8.6 Figure 4 - Dimensions DGF7-18	20
8.7 Figure 5 - Reset/Test connection multiple DGF7-18s	20

1. GENERAL DESCRIPTION

The DGF7-18 is a microprocessor based ground fault unit for use on solidly grounded or resistance grounded systems. This innovative digital electronic unit measures ground fault current using a built-in 28 mm zero sequence Current Sensor (CS), or an external CS. With Control Voltage on, when the measured value reaches or exceeds the setting for current, during the delay time, the unit trips. External CSs with different cable windows, round or square and split core, and various current ratios are available.

The system will react to alternating current (AC) only and will reject direct current (DC) signals. Accuracy will be maintained over a frequency range of 45 - 450 Hz, making it suitable for variable frequency drive applications. The DGF7-18 is a Class A device as defined in the IEC 60755 standard; it is therefore fully characterized for operation with sinusoidal AC and pulsating DC currents.

The maximum system operating voltage for the DGF7-18 is 660 V when passing the system power conductors through the built-in CS. However, by using any GFS external CS and insulating the busbars, or by using any suitably rated, commercially available, interposing CT and passing the secondary lead through the built-in CS, the unit can be used on any system voltage.

The DGF7-18 houses a non-isolated universal power supply from 24 - 240 V AC or DC and is equipped with form 'Z' (4 connections) isolated NO and NC contact sets to operate the upstream protection device and to indicate a failure of the system. The unit will operate in one of two modes: Non-Failsafe or Pulsed Trip/ Auto Reset.

The Ground Fault Current Trip level (30 mA – 6 A, 8 steps) and Trip Delay Time (20 ms (instantaneous), 500 ms) are set on a front accessible dipswitch array.

By double clicking the remote 'RESET' button a functional test of the DGF7-18 is invoked. A single press of a NO remote 'RESET' button resets the unit after a trip. It is not necessary to press a NC remote 'RESET' to invoke Auto Reset.

A green LED indicates three functions: slow flashes denote Control Voltage is present (1 s flashes); steady on after a test was invoked, during delay before test continuous flashes (0,25 s); two fast flashes per second denotes the unit has sensed a ground fault current higher than the Trip Level for a period longer than the Trip Delay Time and that the output contacts have operated (two 0,25 s flashes).

A 10 point Pull-apart terminal block simplifies connection of field wiring.

To ensure that the DGF7-18 will function in severe circumstances, it is encapsulated in polyurethane (PUR) to make sure it is not vulnerable to mechanical shock, vibration nor weather.

2. FUNCTIONALITY

2.1 Dipswitch settings

FOR MAXIMUM SAFETY THE SETTINGS DESCRIBED IN THIS SECTION SHOULD BE MADE WITHOUT CONTROL VOLTAGE AND SYSTEM VOLTAGE APPLIED TO AVOID INADVERTEND TRIPS DURING SET UP.

Should it be necessary to make changes to the dipswitch settings when the DGF7-18 is energised, this can be done without having any adverse effect on the performance of the unit.

The DGF7-18 has dipswitches to set the desired Trip Current Level and Trip Delay time. Below is a summary of the different options. See [table 1](#) for the setting values.

2.1.1 Ground Fault Trip Current level – dipswitches 1, 2 & 3

The DGF7-18 has eight fixed trip points between 30 mA and 6 A of primary fault current. The preferred trip point can be set with dipswitches 1, 2, 3. For values see [table 1](#).

It is recommended that the Ground Fault Trip level is kept as close as possible to the charging current of the system the DGF7-18 is protecting. This will provide maximum safety for operating personnel and equipment.

On resistance grounded systems the Trip Current level should be set lower than 20% of the Neutral Grounding Resistor let-through current.

If the measured ground fault current exceeds the Trip Level setting, the unit will trip after the pre-selected Trip Delay.

2.1.2 Ground Fault Trip Delay Time – dipswitch 4

The G/F Trip Delay time can be 20 ms (instantaneous) or 500 ms. [Table 1](#) provides settings for dipswitch 4.

Set the G/F Trip Delay time to provide the desired delay before the output relay changes state when the G/F Trip Level is reached or exceeded.

The setting should be selected to co-ordinate with other ground-fault devices connected on the same power transformer secondary: set shorter than upstream devices; set longer than downstream devices. If no other ground-fault devices are connected, set for the shortest possible time.

2.2 Operating modes

The DGF7-18 user can select one of two distinct Operating Modes for the device.

All modes have in common:

- In the 'reset state' of the relay the NO¹ contact is open and the NC¹ contact is closed.
- In the 'tripped state' of the relay the NO contact is closed and the NC contact is open.

Each time Control Voltage is applied, the processor of the unit selects the operating mode when it sees an open or closed circuit on terminals R1 and R2. (use a NO or NC pushbutton or a jumper)

- Continuous Non-Failsafe is selected with a closed circuit.
- Auto-Reset, Non-Failsafe is selected with an open circuit.

1. Continuous Non-Failsafe, power-down-reset operation (used for Under Voltage devices)

If during normal operation Control Voltage is removed, the output relay does not change state.

When Control Voltage is restored, the relay remains un-tripped.

If the unit is tripped when Control Voltage is removed, the unit will reset.

If the fault is still present when Control Voltage is restored, the unit will trip after its power-up time.

2. Auto Reset, Non-Failsafe (used for shunt trip devices)

If during normal operation Control Voltage is removed, the output relay does not change state.

When Control Voltage is restored, the relay remains untripped.

The unit resets under one of the following conditions:

- Three seconds after the fault current falls below Trip Level.
- After a short delay after Control Voltage is removed.
- Three second after a test has been performed.

If the fault is still present when Control Voltage is restored, the unit will trip after its power-up time.

Note: if wired as seen in figure 2 this operating mode is used as pulsed trip for the breaker. The pulsed trip prevents damage to the internal mechanism of the circuit breaker in the event that the operator tries to reset the circuit breaker while the trip contact is still closed.

The green LED shows operating state (power on, trip or test). See [section 2.3](#) for LED indicators.

Application information:

- The Non-Failsafe mode can be used when the output relay is operating undervoltage devices. This includes: contactor coils, starter coils and circuit breakers equipped with Under Voltage Release (UVR) trip coils.
- The Pulsed Trip Auto Reset mode is designed for applications where the output relay is operating a shunt trip device.

2.3 LED indicators

The unit has a green 'RUN' LED showing correct operation by slowly flashing (1 s flashes).

When the unit has tripped, the LED will show two 0,25 s flashes.

After a test had been invoked the LED will turn on solidly (during the delay time the LED will show continuous 0,25 s flashes).

2.4 Test/Reset pushbutton

To select Continuous Non-Failsafe or Pulsed Trip/Auto Reset a momentary button must be connected to the DGF7-18 on terminals R1 and R2, this button is used to test and reset the unit.

¹ (NO = Normally Open, NC = Normally Closed)

- For Non-Failsafe operation, connect a NO momentary contact Test/Reset button.
- For Pulsed Trip/Auto Reset operation, connect a NC momentary contact Test/Reset button.

The remote button must be a voltage-free contact; no external power supply is required. See [section 6.3](#). A reset will only be granted if the cause of the trip is cleared. Otherwise the relay will remain activated without glitches.

With the unit in Auto Reset, the relay and LED electronics reset automatically in 3 seconds. The reset button does not have to be pressed.

Double-clicking the button invokes a test which switches an AC test-voltage onto the built-in processor's CS input. The voltage is scaled to simulate a residual current of 1,2 times the G/F trip level. The unit will trip on G/F after the set delay (plus 0,4 s) and then switch off the AC test-voltage. The green LED turns on solidly. While waiting for the delay time to pass, after a test request, the green LED will show continuous 0,25 s flashes.

The reset button needs to be pressed again to reset the unit.

WARNING: invoking a test will and must trip the installation!

2.5 External Current Sensor

Each CS series sensor is epoxy moulded for exceptional mechanical properties and has a high-grade silicon iron core for excellent coupling characteristics under all temperature situations. All CS series current sensors are protected against emitting high voltages when the secondary output is not properly connected. The maximum voltage is 25 V RMS.

Refer to [Figures 1, 2, 3](#) for correctly connecting the CS. Pass the phase conductors through the CS window. If the neutral conductor is being connected downstream, it is to be passed through the window. Do not pass ground conductors through the CS window. In applications that require shielded wires to pass through the CS window, return the shields through the CS window before connecting them to ground.

Position power cables in the centre of the current sensor's window. Keep cables and buswork clear of the split on split core current sensors.

See [section 5](#) for the available Current Sensors.

2.6 Frame Bonding/Chassis Ground

For optimum EMC performance and safety, the FB terminal must be firmly connected to the local frame or chassis ground. The chassis ground must not be more than 50 mm away from the unit.

If the DGF7-18 is mounted on a 35 mm DIN rail, a 'DIN rail ground terminal block' can be installed beside the unit to act as the chassis ground point. Use a 2 - 2,5 mm² (14 AWG) stranded conductor.

[Back to Connections and Precautions.](#)

3. CONTROL VOLTAGE

The DGF7-18 has a universal power supply input, accepting nominal voltages between 24 and 240 V AC or DC with a -20% / +10% tolerance. The total range of accepted voltages is therefore 19,2 to 264 V AC or DC. Power consumption is a mere 1,2 VA maximum with AC voltages and 0,5 W maximum with DC voltages.

Note that the built-in power supply circuit is non-isolated. There is no electrical isolation between the Control Voltage input and the internal electronics, which therefore share a common ground reference. This reference is applied to the system through the FB terminal which must be firmly connected to local frame or chassis ground with a maximum of 50 mm distance from the unit for safety and proper EMC behaviour. Use a 2 - 2,5 mm² (14 AWG) stranded conductor. Control Voltage is subsequently presented to the L+ terminal with respect to chassis ground. AC voltage sources connect their 'cold' FB side to the chassis and distribute their 'hot' L side through wiring to the L+ terminals. DC voltage sources connect their 'cold' – side to the chassis and distribute their 'hot' + side through wiring to the L+ terminal. For good EMC behaviour it is important (as in any installation) to run all wiring close along the chassis or in metal ducts, avoiding excess lengths and coiled up wires.

Cycling the Control Voltage (off/on) resets trip registration when Non-Failsafe operation is selected.

4. CONNECTIONS AND PRECAUTIONS

Please consult the following checklist when installing the DGF7-18.

1. Please review [Figure 1, 2 and 3](#) for typical field connections.
2. Place the DGF7-18 in a clean dry enclosure. Locate the relay in the vicinity of the isolating device (circuit breaker or contactor) that is protecting the circuit being monitored.
3. Provide maximum clearance between the DGF7-18 (plus the external CS, if used) and any strong magnetic flux producing devices such as power transformers, autotransformers, control transformers, reactors, high power conductors, contactors and other buswork.
4. Lead the power conductors of the circuit being monitored (including Neutral if any and excluding the ground wire) through the internal OR external CS's window. WARNING: Never lead conductors through both the internal and the external CS at the same time.
5. All connections to the DGF7-18 are by means of screw clamp pull-apart terminals rated 10 A, 300 V. Terminals will accept 0,14 – 4,0 mm², 26 - 12 AWG solid or stranded conductors. The user may want to identify the following terminals:
 - 13 and 14 for connecting the normally open (NO) contact of the relay.
 - 11 and 12 for connecting the normally closed (NC) contact of the relay.
 - L+ for connecting AC or DC Control Voltage's 'hot' side.
 - FB for providing an absolute ground reference to the system (refer to [section 2.6](#)), use 2-2,5 mm², 14 AWG stranded wire.
 - R1 and R2
 - Non-Failsafe operation: leave these terminals open or connect a NO momentary contact Test/Reset button.
 - Pulsed Trip/Auto Reset operation: install a jumper between these terminals or connect a NC momentary contact Test/Reset button.
 - T1 and T2 for connecting an external CS, use 2 - 2,5 mm², 14 AWG stranded wire. Twist the wires for improved EMC behaviour. The CTs input terminals T1 and T2 are NOT isolated from the Control Voltage. If an external CT is used it is grounded internally via the power supply input and must not be grounded again externally (ground loops). See point 10.
6. See National Electrical Code for minimum required wire gauges.
7. In order to meet the Electromagnetic Compatibility (EMC) requirements a firm and short connection is required between terminal FB and the chassis ground point. The chassis ground must not be more than 50 mm away from the unit.
8. If the DGF7-18 is mounted on a 35 mm DIN rail, a 'DIN rail ground terminal block' can be installed beside the unit to act as the chassis ground point. Use a 2 - 2,5 mm² (14 AWG) stranded conductor.
9. For good EMC behaviour it is important (as in any installation) to run all wiring, especially if unshielded, close along the chassis or in metal ducts, avoiding excess lengths and coiled up wires.
10. Integrate the relay contacts into the projected control circuit. Apply appropriate fusing to protect the contacts (13 A maximum).
11. If an external CS is being used, connect the two secondary terminals of the CS to terminals T1 and T2 of the DGF7-18 using 2 mm² (14 AWG) shielded twisted pair cable. Connect the shield to chassis ground by means of a clamp, close to the DGF7-18 (where the FB terminal is bonded to chassis ground as well). From the clamp to terminals T1 and T2 the wires can be left unshielded. Please note that terminal T1 is internally connected to terminal FB of the DGF7-18. Since terminal FB must be grounded, it means that the external CS will be grounded automatically. If separate grounding is required by electrical regulations, the external CS terminal connected to T1 should be connected to the same grounding point as terminal FB of the DGF7-18. This will avoid ground loops and nuisance tripping.
12. Secure the unit to the DIN rail ensuring the white release latch at the bottom of the unit engages the rail. If the unit is to be mounted in any other position take appropriate steps to prevent the unit from becoming disengaged from the DIN rail.

13. To connect the test/reset button, use a twisted pair cable (of any gauge accepted by the terminals). If the distance between the button and the DGF7-18 exceeds 1 m, shielded cable is recommended, the shield being connected to chassis ground by means of a clamp, close to the DGF7-18 (where the FB terminal is bonded to chassis ground as well). From the clamp to the terminals the wires can be left unshielded.
NOTE: Terminals R1 and R2 are NOT isolated. Terminal R2 is internally connected to terminal FB. The external reset button must be a voltage-free NO or NC contact; no external power supply is required. See [section 6.3](#).
14. Up to six DGF7-18 units in the same enclosure may share a common remote test/reset button. Connect one terminal of the button to terminal R2 of one of the units, and connect the other terminal of the button to terminals R1 of all the units in parallel. Those relays that are to operate in the Pulsed Trip Auto Reset mode should have the R1 terminal of all units connected to a NC Button. Those relays that are to operate in the Non-Failsafe mode should have the R1 terminal of all units connected to a NO Button.
15. Position power cables in the centre of the current sensor window. Keep cables and buswork clear of the split on split core Current Sensors.
16. Verify that the polarity of the conductors is correct when they pass through the CS. Verify that ground paths do not run through the CS, except when applications require shielded wires to pass through the CS window, in that case return the shields through the CS window before connecting them to ground.
17. Phase Conductors must be insulated for the system voltage when it is higher than 660 V.

NOTE: Use the correct type of CS as specified in [section 5](#). The use of standard type of core balance current transformers, connected to the external CS input, may lead to catastrophic failure of the DGF7-18.

5. CATALOGUE NUMBERS

DGF7-18	Ground Fault Protection Unit with built-in 28 mm CS, 24 – 240 V AC or DC Control Voltage, for use on 660 V maximum, 45 - 450 Hz power systems. Optional: external CS and remote Test/Reset button.
CS5-028	Zero sequence current sensor, 28 mm window, 500:1 ratio
CS5-050	Zero sequence current sensor, 50 mm window, 500:1 ratio
CS5-065	Zero sequence current sensor, 65 mm window, 500:1 ratio
CS5-090	Zero sequence current sensor, 90 mm window, 500:1 ratio
CS5-150	Zero sequence current sensor, 150 mm window, 500:1 ratio
CS5-240	Zero sequence current sensor, 240 mm window, 500:1 ratio
CS5-1517	Zero sequence current sensor, 150 x 170 mm window, 500:1 ratio *
CS5-1025	Zero sequence current sensor, 100 x 250 mm window, 500:1 ratio *
CS5-1035	Zero sequence current sensor, 100 x 350 mm window, 500:1 ratio *
CS5-2028	Zero sequence current sensor, 200 x 280 mm window, 500:1 ratio
CS5-3030	Zero sequence current sensor, 300 x 300 mm window, 500:1 ratio *
CS10-095	Zero sequence current sensor, 95 mm window, 1000:1 ratio
CS10-144	Zero sequence current sensor, 144 mm window, 1000:1 ratio
CS10-240	Zero sequence current sensor, 240 mm window, 1000:1 ratio
CS10-1025	Zero sequence current sensor, 100 x 250 mm window, 1000:1 ratio *
CS10-1035	Zero sequence current sensor, 100 x 350 mm window, 1000:1 ratio *
CS10-2028	Zero sequence current sensor, 200 x 280 mm window, 1000:1 ratio
CS20-095	Zero sequence current sensor, 95 mm window, 2000:1 ratio
CS20-144	Zero sequence current sensor, 144 mm window, 2000:1 ratio
CS20-240	Zero sequence current sensor, 240 mm window, 2000:1 ratio
CS20-1025	Zero sequence current sensor, 100 x 250 mm window, 2000:1 ratio *
CS20-1035	Zero sequence current sensor, 100 x 350 mm window, 2000:1 ratio *
CS20-2028	Zero sequence current sensor, 200 x 280 mm window, 2000:1 ratio
CS100-095	Zero sequence current sensor, 95 mm window, 10.000:1 ratio
CS100-144	Zero sequence current sensor, 144 mm window, 10.000:1 ratio
CS100-240	Zero sequence current sensor, 240 mm window, 10.000:1 ratio
CS100-2028	Zero sequence current sensor, 200 x 280 mm window, 10.000:1 ratio

* These current sensors are also available as a split core version, which adds /S to the name, e.g. when ordered the name is CS5-1517/S.

Note 1: all the CS5, CS10, CS20 and CS100 type Current Sensors are for use with Ground Fault Systems devices only.

Note 2: all Ground Fault Systems devices can only be used with CS series sensors, except for interposing CTs with their secondary wiring through the internal CS of the DGF7-18.

Note 3: all CS series current sensors are protected against high voltages when the secondary output is open circuit. The maximum voltage is 25 V RMS.

[Back to External Current Sensor.](#) [Back to Connections and precautions.](#) [Back to 6.1.](#)

6. TECHNICAL SPECIFICATIONS

6.1 Ground fault circuit

G/F Trip Level (settable)	30 – 120 – 210 – 300 – 600 mA and 2,4 – 4,2 - 6 A			
Accuracy of G/F trip point	-15% / +0% of Trip Level ¹			
G/F Trip Delay Time (settable)	20 ms (instantaneous) 500 ms			
Accuracy of G/F Trip Delay Time	-2 / +5 ms or $\pm 2,5\%$ of Trip Delay Time, whichever is greater at > 10 times setting. See also section 6.2 .			
Thermal withstand capability	300 A	indefinitely	1500 A	500 ms
	500 A	2000 ms	≥ 2000 A	300 ms
	1000 A	700 ms		
Thermal withstand capability with external CS Ratio 500:1	300 A	indefinitely	2000 A	125 ms
	500 A	2000 ms	5000 A	20 ms
	1000 A	500 ms		
Thermal withstand capability with external CS Ratio 10.000:1	10.000 A	3,00 s		
	50.000 A	1,00 s		
	200.000 A	0,05 s		
Suitable external Current Sensor types	Different sizes with 500:1, 1000:1, 2000:1 and 10.000:1 ratio, including split rectangular sensors. See section 5 .			

¹ The accuracy of the trip point refers to the value of the real world leakage current (assuming a purely sinusoidal wave shape) that just causes a trip when slowly increased from zero.

6.2 Trip Time Accuracy

The ground fault detection mechanism has a 'thermal' behaviour for greatly reduced noise sensitivity: the quoted delays are valid for sinusoidal currents exceeding the setpoint by >10 times. For reduced current excursions the delay increases as follows:

Trip current settings exceeded by a factor of:	1,2	2	4	>6
Increased Delay by:	60 ms	20 ms	8 ms	3 ms

For IEC 60755 'pulsating DC' currents, the delay increases by a further 50 ms maximum.

6.3 External button

Type of button	Single pole, voltage free, normally open or normally closed, momentary.
Voltage across / current through contact	5 V DC, 1 mA
Maximum number of units that can be controlled in parallel from one voltage-free button	6, all in the same enclosure.

[Back to Test/Reset pushbutton.](#)

[Back to Connections and precautions.](#)

6.4 Control Voltage

Voltage range	Nominal: 24 – 240 V AC/DC
Operating voltage tolerance:	80 - 110% of rated voltage 24 - 32 V AC 55 - 110% of rated voltage 32 - 240 V AC 80 - 110% of rated voltage 24 - 240 V DC Total range: 19,2 - 264 V AC/DC
Frequency range on AC voltages	45 – 450 Hz
Power consumption	1,2 VA @ AC, 0,5 W @ DC
Isolation voltage	Not electrically isolated from electronics
Loss of supply tolerance (no impaired operation)	250 ms @ 24 V AC 1 s @120 V AC 4 s @230 V AC 80 ms @ 24 V DC 350 ms @ 48 V DC 750 ms @110 V DC
Power-up time	Max 500 ms for G/F detection ¹

¹ If a ground fault causing a residual current above the G/F Trip Current Level, is already present when Control Voltage is applied, the system trips just as soon as possible, irrespective of the G/F Trip Delay time setting (rationale: the fault may be present much longer than the delay set).

6.5 System power

Voltage and current range (internal CS)	0 – 660 V AC, 0 – 100 A
Voltage and current range (external CS)	Any, providing the power conductors are insulated for the system voltage.
Frequency range	45 - 450 Hz
Isolation voltage (internal CS)	2,5 kV RMS, 1 minute

6.6 Terminals

Type	Pull-apart
c-UL-us rating	300 V AC, 10 A
VDE rating	250 V AC, 12 A, pollution degree 3, over-voltage category III
Insulation stripping length	7 mm
Torque	0,4 – 0,6 Nm
Field wiring <i>See National Electrical Code for minimum required wire gauges.</i>	0,14 – 4,0 mm ² (VDE) 26 - 12 AWG (UL), Cu or Al, solid or stranded

6.7 Relay contacts

Configuration	Voltage free, 1 NO and 1 NC contact, 4 terminals
c-UL-us rating	<p>5 A @ 250 V AC, general use 5 A @ 30 V DC, resistive 1/6 hp, 250 V AC 2 A, 250 VA, @ 125 V AC, pilot duty 1 A, 250 VA, @ 250 V AC, pilot duty 0,88 A, 26,4 VA, @ 30 V DC, pilot duty</p> <p>B300: 30 A, 3600 VA make, 3 A 360 VA break @ 120 V AC</p> <p>15 A, 3600 VA make, 1,5 A 360 VA break @ 240 V AC</p>
EN 60947 rating	<p>5 A @ 250 V AC utilization category AC-12 4 A @ 250 V AC utilization category AC-13 3 A @ 250 V AC utilization category AC-14 3 A @ 250 V AC utilization category AC-15 5 A @ 30 V DC utilization category DC-12 3 A @ 24 V DC utilization category DC-13 Maximum fuse rating 13 A (EN 60947-5-1)</p>
Isolation voltage between contacts and coil	3 kV RMS, 50 – 60 Hz, 1 minute
Breakdown voltage between open contacts	1 kV RMS, 50 – 60 Hz, 1 minute
Between contact sets	2 kV RMS, 50 - 60 Hz, 1 minute

6.8 Mechanical properties (installed)

See [Figure 4](#)

Height	70 mm
Width	45 mm
Depth (not including terminal block)	91 mm
Depth (including terminal block)	113 mm
Internal CS window diameter	28 mm
DIN rail if DIN rail mounted	35 mm
Screws if screw mounted	M5 x 20 (2 needed)
Weight (open)	0,35 kg
Weight (packaged)	0,40 kg

6.9 Environment

Operating temperature	-35 °C to +60 °C
Storage temperature	-40 °C to +80 °C
Humidity	85% max. (no condensation)
Ingress protection	IP20
Mechanical shock resistance (no malfunction)	10 G
Vibration resistance (no malfunction)	10 G, 10 – 55 Hz at 1,5 mm double amplitude

The DGF7-18 is encapsulated in polyurethane (PUR) to keep the exposure to mechanical shock, vibration and weather to a minimum.

7. APPLICABLE STANDARDS

EN 61000-6-3	Electromagnetic compatibility (EMC) – Part 6-3: Generic standards – Emission standard for residential (=lowest levels). 30- 230 MHz 30 dB μ V at 10 m distance 230-1000 MHz 37 dB μ V at 10 m distance
EN 61000-6-4	Electromagnetic compatibility (EMC) Part 6-4: Generic standards - Emission standard for industrial environments.
EN 61000-6-8	Electromagnetic compatibility (EMC) – Part 6-8: Generic standards – Emission standard for professional equipment in commercial and light-industrial locations.
EN 61000-6-2	Electromagnetic compatibility (EMC) – Part 6-2: Generic standards – Immunity standard for industrial environments (=highest levels) 80-1000 MHz with 80% AM modulation up to 10 V/m at 3 m distance from source.
EN 61000-4-2	Electromagnetic compatibility (EMC) - Part 4-2: Testing and measurement techniques - Electrostatic discharge immunity test.
EN 61000-4-3	Electromagnetic compatibility (EMC) - Part 4-3: Testing and measurement techniques - Radiated, radio-frequency, electromagnetic field immunity test.
EN 61000-4-4	Electromagnetic compatibility (EMC) Part 4-4: Testing and measurement techniques - Electrical fast transient/burst immunity test.
EN 61000-4-5	Electromagnetic compatibility (EMC) Part 4-5: Testing and measurement techniques - Surge immunity test.
EN 61000-4-6	Electromagnetic compatibility (EMC) Part 4-6: Testing and measurement techniques - Immunity to conducted disturbances, induced by radio-frequency fields.
EN 61000-4-11	Electromagnetic compatibility (EMC) Part 4-11: Testing and measurement techniques - Voltage dips, short interruptions and voltage variations immunity tests for equipment with input current up to 16 A per phase.
EN 60947-5-1	Low-voltage switchgear and controlgear – Part 5-1: Control circuit devices and switching elements – Electromechanical control circuit devices.
IEC 60755	General requirements for residual current operated protective devices
c-UL-us	UL 1053 UL standard for Safety Ground-Fault Sensing and Relaying Equipment, Class 1. CSA C22.2 NO. 144-M1991 CSA standard for Ground Fault Circuit Interrupters. File E203514
CE	CE mark – Declaration of Conformity

8. TABLES AND FIGURES

8.1 Table 1 - Dipswitch settings

'R' denotes right and 'L' denotes left.

Values are primary currents for a 500:1 ratio internal or external Current Sensor. For other ratio's see Table 2.

Switch no.	Parameter	Set to	Meaning
1 2 3	Ground Fault Trip level	R L L R L R R R L R R R ♦ L L L L L R L R L L R R	0,030 A 0,120 A 0,210 A 0,30 A 0,60 A 2,4 A 4,2 A 6,0 A
4	Ground Fault Trip Delay time	R ♦ L	20 ms (instantaneous) 500 ms
♦ Factory settings			

[Back to Dipswitch settings.](#)

8.2 Table 2 - Primary current Trip level

Values are primary currents.

DGF7-18 Setting	External current sensor ratio's				Interposing CT ratio's	
	500:1	1000:1	2000:1	10.000:1	500:5	5000:5
0,030 A	0,030 A	0,060 A	0,120 A	0,60 A	3,00 A	0,030 kA
0,120 A	0,120 A	0,240 A	0,480 A	2,40 A	12,0 A	0,120 kA
0,210 A	0,210 A	0,420 A	0,840 A	4,20 A	21,0 A	0,210 kA
0,30 A	0,30 A	0,60 A	1,20 A	6,00 A	30,0 A	0,3 kA
0,60 A	0,60 A	1,20 A	2,40 A	12,0 A	60,0 A	0,6 kA
2,4 A	2,4 A	4,8 A	9,6 A	48,0 A	240 A	2,4 kA
4,2 A	4,2 A	8,4 A	16,8 A	84,0 A	420 A	4,2 kA
6,0 A	6,0 A	12,0 A	24,0 A	120,0 A	600 A	6,0 kA

8.3 Figure 1 - Typical Field Connection using built-in CS, contactor and Test/Reset (NO)

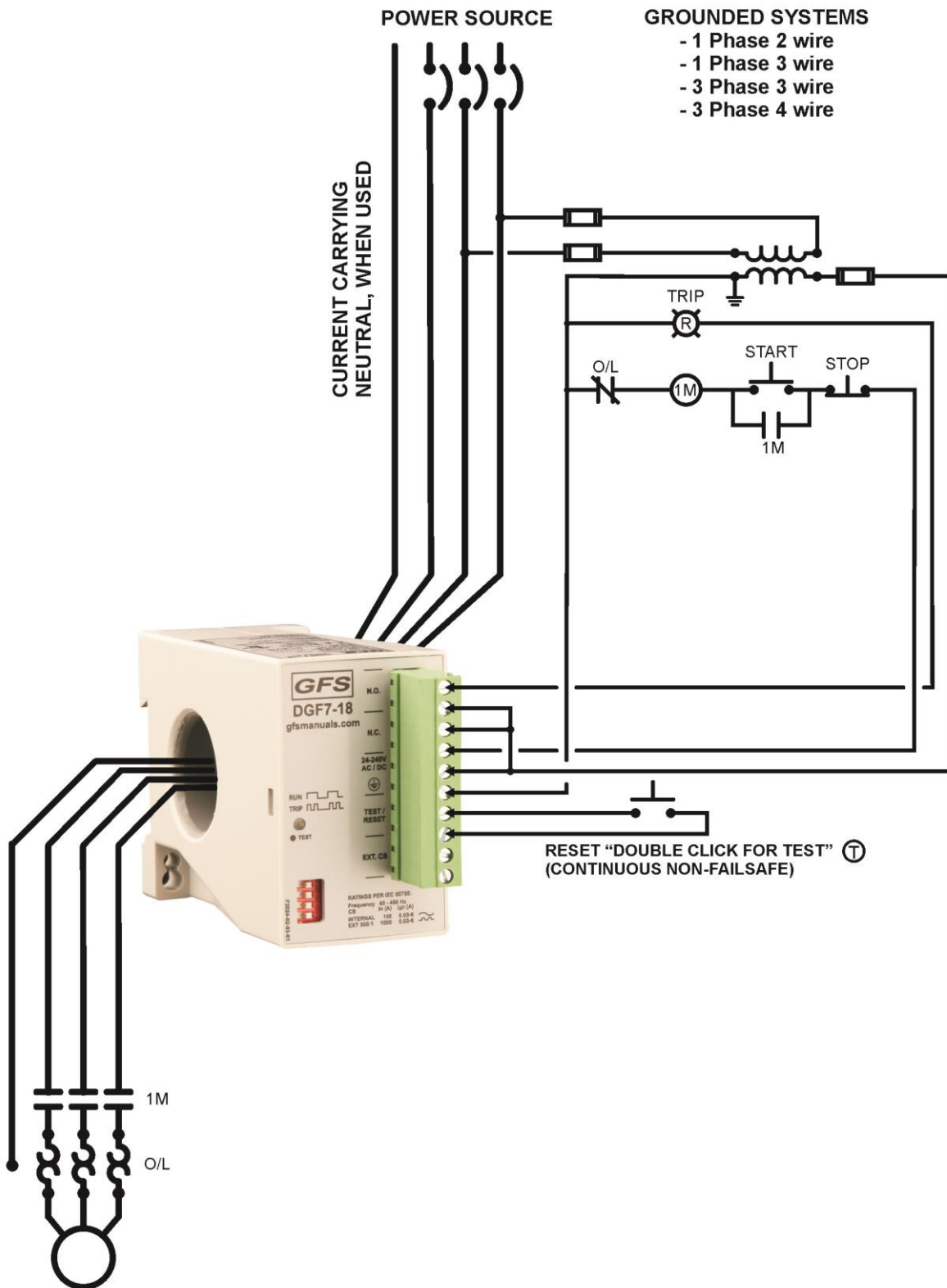

8.4 Figure 2 - Typical field connection with external CS, shunt trip and Test/Reset (NC)

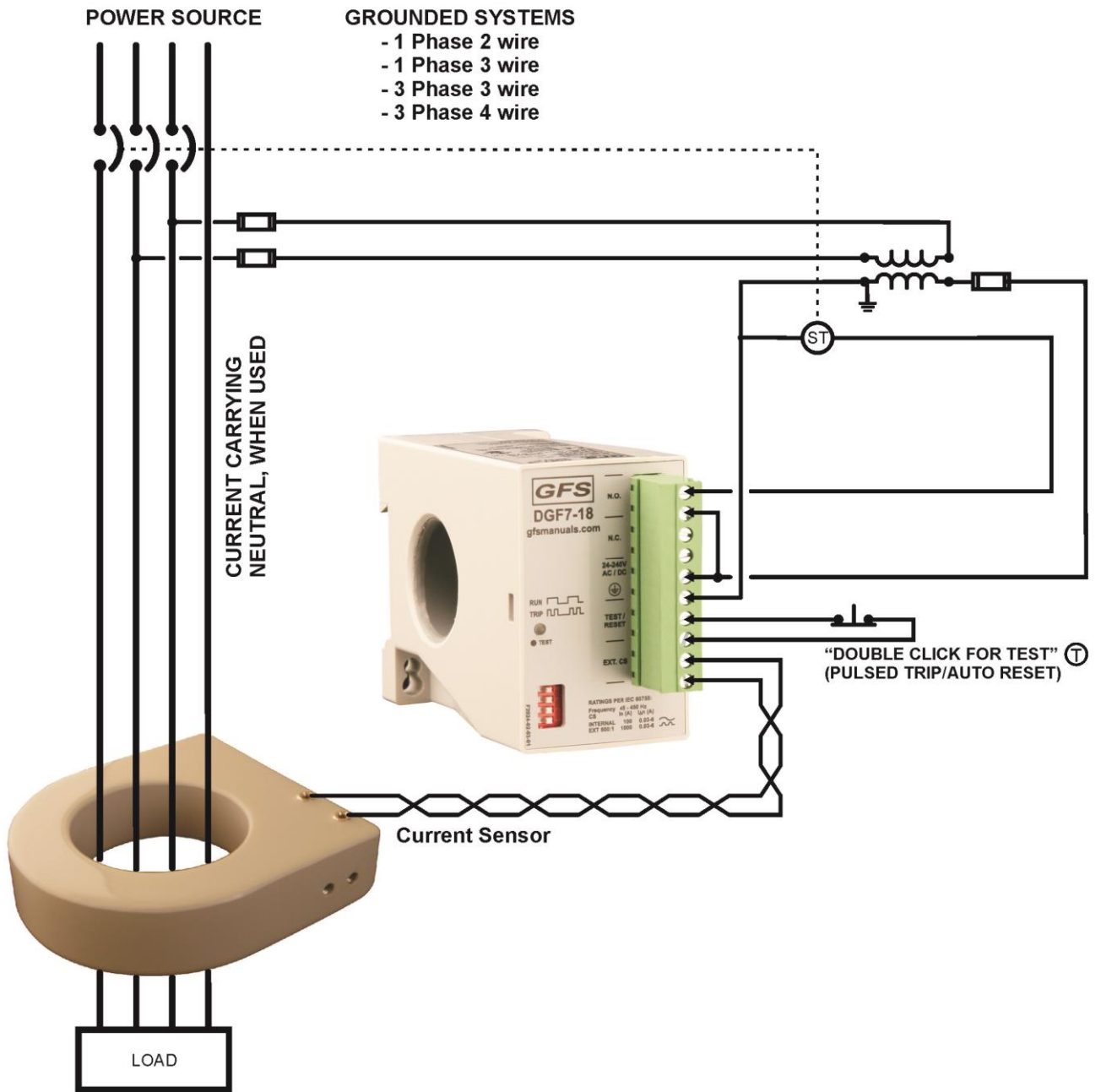

8.5 Figure 3 - Typical field connection with interposing CT, shunt trip and Test/Reset (NC)

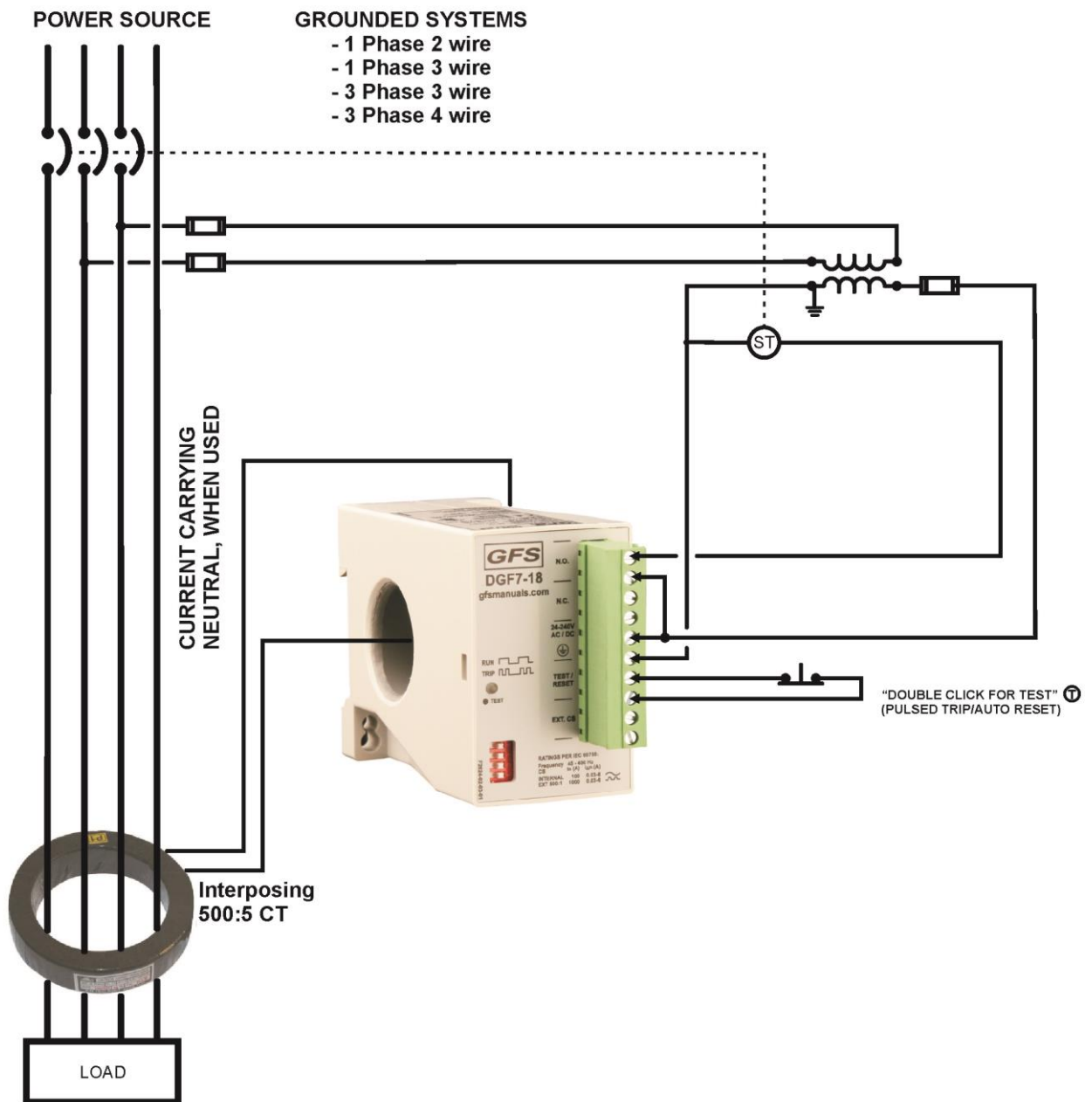

8.6 Figure 4 - Dimensions DGF7-18

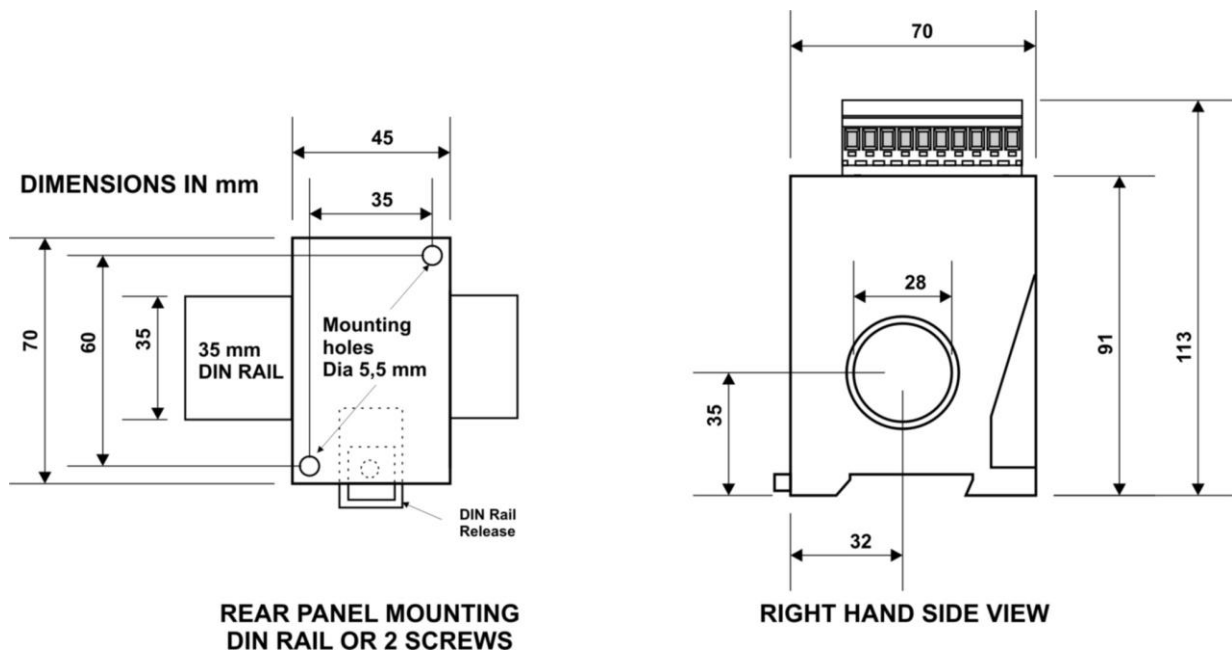

8.7 Figure 5 - Reset/Test connection multiple DGF7-18s

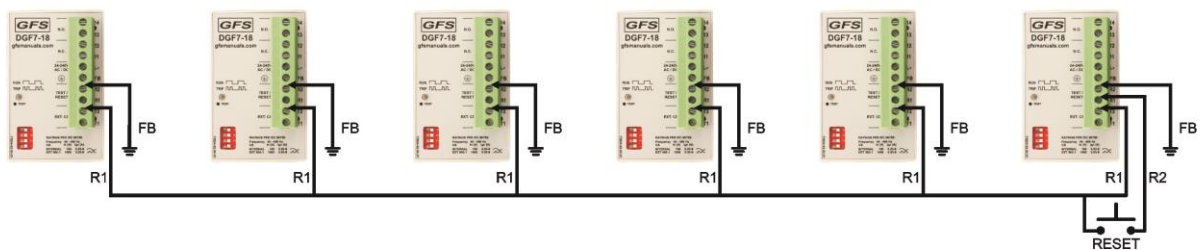

Connection of up to six DGF7-18s in the same enclosure with one Reset/Test button

Button to select operating mode:
 N.O. for Non-Failsafe
 N.C. for Pulsed Trip/Autoreset