

DGF7-30 Intelligent Ground Fault Protection reference manual

SERIES C AND D



Ground Fault Systems bv

Ground Fault Systems B.V.
Rijtersbleek-Aalten 4B15
7521 RB Enschede
The Netherlands

www.groundfaultsystems.com
info@groundfaultsystems.com
Tel: +31 53 4318628
CofC: 55400914

1. GENERAL DESCRIPTION	3
2. FUNCTIONALITY	4
2.1 Dipswitch settings	4
2.1.1 Ground Fault Trip Current level – dipswitches 1, 2 & 3	4
2.1.2 Ground Fault Trip Delay Time and Trip Inhibit – dipswitches 4, 5 & 6	4
2.1.3 Operating modes – dipswitches 7 & 8	4
2.1.4 Tamper proof dipswitches	5
2.2 Trip Inhibit	6
2.2.1 UL Standards	6
2.3 LED indicators	7
2.4 Memory after loss of Control Voltage	7
2.5 Reset/Test pushbutton	7
2.6 External Current Sensor	8
2.7 Frame Bonding/Chassis Ground	8
3. CONTROL VOLTAGE	9
4. CONNECTIONS AND PRECAUTIONS	10
5. CATALOGUE NUMBERS	12
6. TECHNICAL SPECIFICATIONS	13
6.1 Ground fault circuit	13
6.2 Trip Time Accuracy	13
6.3 External Current Sensor Supervision circuit	14
6.4 Control Voltage	14
6.5 System power	14
6.6 Terminals	15
6.7 Relay contacts	15
6.8 Mechanical properties (installed)	16
6.9 Environment	16
7. APPLICABLE STANDARDS	17
8. TABLES AND FIGURES	18
8.1 Table 1 - Dipswitch settings	18
8.2 Table 2 - Primary current Trip level and High Current level	19
8.3 Figure 1 - Typical field connection with a shunt trip device and external Current Sensor	20
8.4 Figure 2 - Typical field connection with a start-stop device and external Current Sensor	21
8.5 Figure 3 - Dimensions DGF7-30	22

1. GENERAL DESCRIPTION

The DGF7-30 is a microprocessor based ground fault unit for use on solidly grounded or resistance grounded systems. This innovative digital electronic unit measures ground fault current using an external CS. With Control Voltage on, when the measured value reaches or exceeds the setting for current, during the delay time, the unit trips. External CSs with different cable windows, round or square and split core, and various current ratios are available. The DGF7-30 can detect a connection failure, open or shorted wires, of the external CS. Both situations will call for a trip of the system, as it is unprotected from there on. This function is only available in the C series, not in the D series.

The system will react to alternating current (AC) only and will reject direct current (DC) signals. Accuracy will be maintained over a frequency range of 45 - 450 Hz, making it suitable for variable frequency drive applications. The DGF7-30 is a Class A device as defined in the IEC 60755 standard; it is therefore fully characterized for operation with sinusoidal AC and pulsating DC currents.

The DGF7-30 can be used on any system operating voltage, providing the power conductors passing through the external GFS CS are insulated for the system voltage and electrical clearance requirements are met.

The DGF7-30 houses a non-isolated universal power supply from 24 - 240 V AC or DC and is equipped with form 'Z' (4 connections) isolated NO and NC contact sets to operate the upstream protection device and to indicate a failure of the system. The Ground Fault Current Trip level (30 mA – 9 A, 8 steps), Trip Delay Time (20 ms – 10 s, 6 steps), Trip Inhibit (enabled/disabled) and the Relay Operating Mode (Continuous Non-Failsafe, Continuous Failsafe, Pulsed Non-Failsafe, Pulsed Failsafe) are set on a front accessible dipswitch array. The dipswitch array is made 'tamper proof', meaning that manipulating the switches will not change the settings, unless a special procedure is followed. If the procedure is not followed correctly the red and green LEDs will flash alternately, indicating an attempt to illegally change the settings. The original settings will stay valid until the entire procedure is followed.

The measured current is compared against two setpoints. The lower one is the Ground Fault (G/F) setpoint, the higher one is the High Current (H/C) setpoint. Using different ratio Current Sensors will influence the setpoint, as outlined in [table 2](#).

When the current exceeds the G/F setpoint during the set delay, but does not reach the H/C level, a 'G/F' is diagnosed and the unit trips by operating its internal relay. Should a fault be approaching a dead short to ground, causing a residual current exceeding the H/C setpoint, then without any intentional delay the unit operates its relay, indicating a Short Circuit 'S/C'.

The user can select the operation of the relay to be 'Trip Inhibited'. Together with an upstream tripping device (fuses or breaker) it can protect local contactor contacts in the case of H/C faults. In this case the unit does not trip initially when the measured current exceeds the H/C setpoint, but waits for the upstream device to take care of current interruption and then trips. The latter trip flags the location of the fault to the user and also allows, after inspection for welded contacts, fast re-closure of the upstream tripping device. Should the upstream device fail to perform, then automatic backup protection makes the DGF7-30 trip, as a last resort, one second after the H/C occurred. This makes it possible to design a Type 2 coordinated installation, according to the IEC 60755 standard and a Class 2, according to the UL 1053 standard.

A single press of the 'RESET' button resets the unit after a trip. A functional test of the DGF7-30 is started by double clicking the cover mounted pushbutton.

WARNING: invoking a test will and must trip the installation!

A green 'RUN' LED flashes, alternating one second on and off, to indicate that sufficient Control Voltage is applied (Power OK).

A red 'TRIP' LED indicates that the DGF7-30 has sensed a fault and that the output contacts have operated. The blinking sequence of the red LED indicates the type of fault. When the power to the DGF7-30 is removed, pressing the cover mounted reset button will show the green LED when no fault was there before power-down. If a fault was present before power-down, the red LED will indicate the fault by the blinking sequence. The fault can only be reset when Control Voltage is present.

An 8 point Pull-apart terminal block simplifies connection of field wiring.

To ensure that the DGF7-30 will function in severe circumstances, it is encapsulated in polyurethane (PUR) to make sure it is not vulnerable to mechanical shock, vibration nor weather.

2. FUNCTIONALITY

2.1 Dipswitch settings

The DGF7-30 has dipswitches to set the desired Trip Current Level, Trip Delay time, Trip Inhibit and Relay Operating Mode. Below is a summary of the different options. See [table 1](#) for the setting values and [section 2.1.4](#) about tamper proof dipswitches.

Warning: due to the procedure of setting up the dipswitches the installation will trip while changing the settings.

2.1.1 Ground Fault Trip Current level – dipswitches 1, 2 & 3

The DGF7-30 has eight fixed trip points between 30 mA and 9 A of primary fault current. The preferred trip point can be set with dipswitches 1 – 3. For values see [table 1](#). It is recommended that the Ground Fault Trip level is kept as close as possible to the charging current of the system the DGF7-30 is protecting. This will provide maximum safety for operating personnel and equipment.

On resistance grounded systems the Trip Current level should be set lower than 20% of the Neutral Grounding Resistor let-through current.

If the measured ground fault current exceeds the Trip Level setting, the unit will trip after the pre-selected Trip Delay.

2.1.2 Ground Fault Trip Delay Time and Trip Inhibit – dipswitches 4, 5 & 6

The G/F Trip Delay time can be 20 or 300 ms, with or without Trip Inhibit, and 1, 2, 5 or 10 seconds without Trip Inhibit. [Table 1](#) provides settings for dipswitches 4, 5 & 6.

Set the G/F Trip Delay time to provide the desired delay before the output relay changes state when the G/F Trip Level is reached or exceeded.

After the G/F Trip Delay Time has expired the red 'TRIP' LED shows short 0,25 s flashes as a code indicating the cause of the trip. See [section 2.3](#) for the LED indicators.

The setting should be selected to co-ordinate with other ground-fault devices connected on the same power transformer secondary: set shorter than upstream devices; set longer than downstream devices. If no other ground-fault devices are connected, set for the shortest possible time.

If the current exceeds H/C, without Trip Inhibit selected, the unit will trip instantaneously.

2.1.3 Operating modes – dipswitches 7 & 8

The DGF7-30 user can select one of four distinct Operating Modes for the device.

All modes have in common:

- In the 'reset state' of the relay the NO¹ contact is open and the NC¹ contact is closed.
- In the 'tripped state' of the relay the NO contact is closed and the NC contact is open.

See [Table 1](#) for the corresponding dipswitch settings.

The different modes are listed below:

1. Continuous Non-Failsafe, manual-reset operation (used for Under Voltage devices)

If during normal operation Control Voltage is removed, the output relay does not change state.

When Control Voltage is restored, the relay remains untripped.

If the unit is tripped when Control Voltage is removed, the output relay will reset.

If the fault is still present when Control Voltage is restored, the unit will trip after its power-up time.

¹ (NO = Normally Open, NC = Normally Closed)

2. Continuous Failsafe, manual-reset operation (used for Under Voltage devices)
When Control Voltage is removed the relay goes to the tripped state unconditionally. When Control Voltage is restored, without a fault, the unit will reset after its power-up time.
If there is a fault present when Control Voltage is removed or restored the unit stays tripped.
3. Pulsed Non-Failsafe operation (used for shunt controlled breakers)
When a trip occurs, the relay goes to the tripped state for 0,5 s, and then reverts back. Should the measured current remain above the set G/F trip level, then this pulse is repeated every 3 s. If the DGF7-30 trips because of a connection failure of the external CS or test, the pulse will be issued once. The red LED remains active (until one of the reset buttons is pressed or there is no fault present when Control Voltage is restored) enabling the user to verify which DGF7-30 tripped its associated breaker. If one forgets to reset the unit, then the functionality of the trip circuit is not impaired; in other words, in case of a trip condition the relay will correctly issue a pulse, even if the red LED is active.
When Control Voltage is removed the relay will not issue a pulse.
4. Pulsed Failsafe operation (used for Under Voltage shunt controlled breakers)
When Control Voltage is removed the relay will unconditionally issue a 0,2 - 0,3 s pulse. When a trip occurs, the relay goes to the tripped state for 0,5 s and then reverts back. Should the measured current remain above the set G/F trip level, then this pulse is repeated every 3 s. If the DGF7-30 trips because of a connection failure of the external CS or test, the pulse will be issued once. The red LED remains active (until one of the reset buttons is pressed or when Control Voltage is restored without a fault) enabling the user to verify which DGF7-3 tripped its associated breaker. If one forgets to reset the unit, then the functionality of the trip circuit is not impaired; in other words, in case of a trip condition the relay will correctly issue a pulse, even if the red LED is active.

The green LED will indicate normal running operation, the red LED will indicate a fault code. This fault code can be viewed when the unit is on or while pressing the cover mounted button when Control Voltage is removed. See [section 2.3](#) for LED indicators and [section 2.4](#) for Memory after loss of Control Voltage.

Application information:

- The Continuous Failsafe and Non-Failsafe modes can be used when the output relay is operating undervoltage devices. This includes: contactor coils, starter coils and circuit breakers equipped with Under Voltage Release (UVR) trip coils.
- The Pulsed Failsafe and Non-Failsafe modes are designed for applications where the output relay is operating a shunt trip device. The output contact to the shunt trip coil opens after a successful trip. This prevents damage to the internal mechanism of the circuit breaker in the event that the operator tries to reset the circuit breaker while the trip contact is still closed.

If the DGF7-30 is to be used for alarm only purposes (rather than to interrupt ongoing processes), and the alarm has to have an auto-resetting nature, then one has to resort to one of the Pulsed modes. The pulses will be repeated as long as current is above the set G/F level. Note, however, that a badly connected external CS would only generate one pulse. Also note that with ground faults the red LED will always show the 'trip failed' alarm.

[Back to Reset/Test pushbutton.](#)

[Back to Control Voltage.](#)

2.1.4 Tamper proof dipswitches

Eight dipswitches enable the user to tailor the DGF7-30 to the installations needs. However, to discourage unauthorized manipulation, settings (as opposed to switches) can only be changed by going through a procedure. When an attempt is made to change the settings without going through the procedure, the green and red LEDs start to blink alternately until the switches are returned to their original positions. Should the switches be left deviating from the original positions, the original settings, stored in non-volatile memory, remain valid. The unit will not trip in this situation.

Contact us at info@groundfaultsystems.com for the procedure or look in the paper manual included with the unit.

[Back to Dipswitch settings.](#)

[Back to LED indicators.](#)

[Back to Table 1.](#)

2.2 Trip Inhibit

Contactors are not designed to interrupt high fault currents. The Trip Inhibit function is useful when the Ground Fault unit is used to trip a contactor or motor starter on a solidly grounded system. In this application, there is no defined limit to the magnitude of the ground fault current, should a bolted ground fault occur. Under these conditions the upstream short circuit protective device, fuses or circuit breaker, should interrupt the fault. If the ground fault current exceeds the H/C level, the unit will be inhibited from tripping until the ground fault current drops below the High Current level. After the current drops below H/C as a result, the DGF7-30 activates its trip relay to isolate the faulty circuitry. However, should the current fail to drop, then, as a last resort, the unit will trip within 20 or 300 ms (selected by dipswitch), showing the cause of the trip on its red LED.

In relation to IEC standard 60947-4-1 it is now possible to construct a 'Type 2 coordinated' installation:

- Only minor welding of the contactor or starter contacts is permissible and the contacts must be easily separated.
- Following Type 2 coordination tests, the switchgear and control gear functions must be fully operational.

It is advisable to inspect the contactor after a Trip Inhibit event occurred since it was used to break a current, possibly outside its rating. Even if the current was inside the rating, minor welding of the contacts can occur. The cause of the trip and the location of the trip are indicated so, after a quick inspection of the affected contactor, the power on the remaining part of the installation can be restored.

2.2.1 UL Standards

- These requirements cover ground-fault current sensing devices, relaying equipment, or combinations of ground-fault current sensing devices and relaying equipment or equivalent protection equipment for use in ordinary locations that will operate to cause a disconnecting device to open all ungrounded conductors at predetermined values of ground-fault current, in accordance with the National Electrical Code, ANSI/NFPA 70.
- These requirements cover equipment intended for use in circuits that are solidly grounded.
- These requirements do not cover equipment intended to be powered from single-phase circuits operating at more than 600 volts or three-phase circuits operating at more than 600 volts phase-to-phase.
- These requirements do not cover ground-fault circuit-interrupters.
- These devices are intended to operate with shunt-trip circuit breakers, electrically tripped bolted pressure contact switches and the like that constitute the disconnecting means.
- Class I ground-fault protection device is one that does not incorporate means to prevent opening of the disconnecting means at high levels of fault current and is intended for use with the following:
 - a. Circuit breakers,
 - b. Fused circuit breakers,
 - c. Fused switches having an interrupting rating not less than 12 times their ampere rating, or
 - d. Fused switches having integral means to prevent disconnecting at levels of fault current exceeding the contact interrupting rating of the switch.
- A Class II ground-fault protection device is one that incorporates means to prevent initiation of opening of the disconnecting device if the fault current exceeds the contact interrupting capability of the disconnecting device with which it is intended to be used.
- These requirements cover enclosed-type devices and also cover open-type devices that are intended for use in other equipment, such as panelboards, switchboards, and the like.

The DGF7-30 is a Class I ground-fault protection device if Trip Inhibit is not enabled.

Enabling Trip Inhibit makes the DGF7-30 a Class II ground-fault protection device.

2.3 LED indicators

The unit has a green 'RUN' LED showing correct operation by slowly flashing (1 s flashes). The green 'RUN' LED will blink 0,25 s on/off during the delay time. After the delay time has expired, the unit will trip and the red 'TRIP' LED shows short 0,25 s flashes as a code indicating the cause of the trip:

- 1 flash = 'G/F'. Residual current exceeded the set G/F limit, but did not reach H/C levels.
- 2 flashes = 'S/C'. Residual current exceeded the H/C level, without Trip Inhibit. (See table 2) In case Trip Inhibit is used, this code also means the upstream device tripped correctly. After the current goes to zero as a result, the DGF7-30 activates its trip relay to isolate the faulty circuitry.
- 3 flashes = 'BACKUP'. This trip can only occur when Trip Inhibit is used. Residual current exceeded the H/C level, but the upstream device failed to trip. The DGF7-30 then tripped as a last resort. The contactor should be inspected since its contacts may well be damaged.
- 4 flashes = 'CS'. External CS connection failure. Either shorted or open wires to the External CS. This error is latched, so intermittent failures are captured. This function is not available in the D series.
- 5 flashes = 'F/S CV LOSS'. When in Failsafe mode, trip on loss of Control Voltage.
- Continuous flashing = 'TRIP FAILED'. A trip state on top of one of the possible trips described above. Residual current remained high after a trip. Pressing reset clears this trip, but not yet the trip state, such that the red LED will now show the original trip's flashing code.
- Solid = Tripped after a Test Request.

If the green and red LED blink alternately the tamper proof dipswitch function is active. See [section 2.1.4](#).

[Back to Dipswitch settings.](#)

[Back to Operating Mode.](#)

2.4 Memory after loss of Control Voltage

When Control Voltage is removed from the DGF7-30, the condition of the relay will be memorized (for at least one week or until the memory is read by pressing the reset button). Pressing the reset pushbutton before restoring Control Voltage will light either the green LED or the red LED, green indicating no trip was registered and red indicating the opposite. The green LED will light continuously, whereas the red LED will give a sequence of short flashes as described in [section 2.3](#) indicating the cause of trip.

[Back to Operating Modes](#)

2.5 Reset/Test pushbutton

The built-in button is used to reset the internal relay and the red LED (depending on the Operating Mode, see [section 2.1.3](#)).

A reset will only be granted if the cause of the trip is cleared. Otherwise the relay will remain activated without glitches. If the cause of the trip is cleared but another one is lurking, then pressing the local button will reset the trip indication on the red LED, such that the new trip code can be shown. However, the relay will remain in the trip state, without glitches.

Double-clicking the local button invokes a test which switches an AC test-voltage onto the built-in processor's CS input. The voltage is scaled to simulate a residual current of 1,5 - 3 times the G/F trip level. During the test request, the green LED will show a fast blink (0,25 s flashes). The unit will trip on G/F after the set delay (plus 0,4 s) and then switches off the AC test-voltage. The red LED turns on solidly.

The button needs to be pressed again to reset the unit.

WARNING: invoking a test will and must trip the installation!

2.6 External Current Sensor

Each CS series sensor is epoxy moulded for exceptional mechanical properties and has a high-grade silicon iron core for excellent coupling characteristics under all temperature situations. All CS series current sensors are protected against emitting high voltages when the secondary output is not properly connected. The maximum voltage is 25 V RMS.

The DGF7-30 C detects a connection failure of the external CS.

With any G/F protection scheme using an external CS there is an inherent risk that ground faults will not be detected because of a bad or deteriorated connection to the CS. Both open circuits and shorts on the CS connection will prevent detection of a ground fault current. Therefore, the conventional practice is to prove correct tripping regularly by means of current injection. This is an annoying procedure disrupting normal plant operation. The DGF7-30 C solves this problem by constantly supervising the connection to the external CS. Open circuits as well as shorts are detected and will cause a trip.

When using certain types of variable frequency drives the connection supervising feature will be compromised. These drives misuse the connections with high frequency signals to check their own operation. Therefore a false open/shorted indication will be issued. To prevent conflict between these systems our D series is designed.

Please note that the DGF7-30 C does not employ any DC injection to implement the supervision feature. Even small DC currents sent through the secondary of a CS can bias its core enough to shift the trip point outside specification on sensitive settings. For the CS supervision feature to work the proper Current Sensors, as described in [section 5](#), must be used. See [table 2](#) for the various trip values.

Refer to [Figure 1](#) for correctly connecting the CS. Pass the phase conductors through the CS window. If the neutral conductor is being connected downstream, it is to be passed through the window. Do not pass ground conductors through the CS window. In applications that require shielded wires to pass through the CS window, return the shields through the CS window before connecting them to ground.

Position power cables in the centre of the current sensor's window. Keep cables and buswork clear of the split on split core current sensors.

2.7 Frame Bonding/Chassis Ground

For optimum EMC performance and safety, the FB (Frame Bond) terminal must be firmly connected to the local frame or chassis ground. The chassis ground must not be more than 50 mm away from the unit.

If the DGF7-30 is mounted on a 35 mm DIN rail, a 'DIN rail ground terminal block' can be installed beside the unit to act as the chassis ground point. Use a 2 - 2,5 mm² (14 AWG) stranded conductor.

[Back to Connections and Precautions.](#)

3. CONTROL VOLTAGE

The DGF7-30 has a universal power supply input, accepting nominal voltages between 24 and 240 V AC or DC with a -20% /+10% tolerance. The total range of accepted voltages is therefore 19,2 to 264 V AC or DC. Power consumption is a mere 1,2 VA maximum with AC voltages and 0,5 W maximum with DC voltages.

Note that the built-in power supply circuit is non-isolated. There is no electrical isolation between the Control Voltage input and the internal electronics, which therefore share a common ground reference. This reference is applied to the system through the FB (Frame Bond) terminal which must be firmly connected to local frame or chassis ground with a maximum of 50 mm distance from the unit for safety and proper EMC behaviour. Use a 2 - 2,5 mm² (14 AWG) stranded conductor. Control Voltage is subsequently presented to the L+ terminal with respect to chassis ground. AC voltage sources connect their 'cold' FB side to the chassis and distribute their 'hot' L side through wiring to the L+ terminals. DC voltage sources connect their 'cold' – side to the chassis and distribute their 'hot' + side through wiring to the L+ terminal. For good EMC behaviour it is important (as in any installation) to run all wiring close along the chassis or in metal ducts, avoiding excess lengths and coiled up wires.

4. CONNECTIONS AND PRECAUTIONS

Please consult the following checklist when installing the DGF7-30.

1. Please review [Figure 1 and 2](#) for typical field connections.
2. If the DGF7-30 is used for alarming only purposes, or if the G/F Trip Delay Time is set to 1 s or higher, verify that the DGF7-30 cannot be subjected to conditions exceeding its Thermal Withstand Capability (see [section 6.1](#)).
3. Place the DGF7-30 in a clean dry enclosure. Locate the relay in the vicinity of the isolating device (circuit breaker or contactor) that is protecting the circuit being monitored.
4. Provide maximum clearance between the DGF7-30, the external CS and any strong magnetic flux producing devices such as power transformers, autotransformers, control transformers, reactors, high power conductors, contactors and other buswork.
5. Lead the power conductors of the circuit being monitored (including Neutral if any and excluding the ground wire) through the external CS's window.
6. All connections to the DGF7-30 are by means of screw clamp pull-apart terminals rated 10 A, 300 V. Terminals will accept 0,14 – 4,0 mm², 26-12 AWG solid or stranded conductors. The user may want to identify the following terminals:
 - T1 and T2 for connecting the external CS, use 2 - 2,5 mm², 14 AWG stranded wire.
 - FB for providing an absolute ground reference to the system (refer to [section 2.7](#)), use 2 - 2,5 mm², 14 AWG stranded wire.
 - L+ for connecting AC or DC Control Voltage's 'hot' side.
 - 11 and 12 for connecting the normally closed (NC) contact of the relay.
 - 13 and 14 for connecting the normally open (NO) contact of the relay.
7. See National Electrical Code for minimum required wire gauges.
8. In order to meet the Electromagnetic Compatibility (EMC) requirements a firm and short connection is required between terminal FB and the chassis ground point. The chassis ground must not be more than 50 mm away from the unit.
9. If the DGF7-30 is mounted on a 35 mm DIN rail, a 'DIN rail ground terminal block' can be installed beside the unit to act as the chassis ground point. Use a 2 - 2,5 mm² (14 AWG) stranded conductor.
10. For good EMC behaviour it is important (as in any installation) to run all wiring, especially if unshielded, close along the chassis or in metal ducts, avoiding excess lengths and coiled up wires.
11. Integrate the relay contacts into the projected control circuit. Apply appropriate fusing to protect the contacts (13 A maximum).
12. The external CS must be connected to T1 and T2 of the DGF7-30 using 2 – 2,5 mm² (14 AWG) shielded twisted pair cable. Connect the shield to chassis ground by means of a clamp, close to the DGF7-30 (where the FB terminal is bonded to chassis ground as well). From the clamp to terminals T1 and T2 the wires can be left unshielded.
Please note that terminal T1 is internally connected to terminal FB of the DGF7-30. Since terminal FB must be grounded, it means that the external CS will be grounded automatically. If separate grounding is required by electrical regulations, the external CS terminal connected to T1 should be connected to the same grounding point as terminal FB of the DGF7-30. This will avoid ground loops and nuisance tripping.
13. Secure the unit to the DIN rail ensuring the white release latch at the bottom of the unit engages the rail. If the unit is to be mounted in any other position take appropriate steps to prevent the unit from becoming disengaged from the DIN rail.
14. Position power cables in the centre of the current sensor window. Keep cables and buswork clear of the split on split core Current Sensors.
15. Verify that the polarity of the conductors is correct when they pass through the CS. Verify that ground paths do not exist that would bypass the CS.

16. Phase Conductors must be insulated for the system voltage when it is higher than 660 V.

NOTE: Use the correct type of CS as specified in [section 5](#). The use of standard type of core balance current transformers, connected to the external CS input, may lead to catastrophic failure of the DGF7-30.

5. CATALOGUE NUMBERS

DGF7-30 C	Ground Fault Protection Unit 24 – 240 V AC or DC Control Voltage, for use on any system operating voltage and 45 - 450 Hz power systems, with external CS supervision. To be used with an external GFS CS series current sensor.
DGF7-30 D	Ground Fault Protection Unit 24 – 240 V AC or DC Control Voltage, for use on any system operating voltage and 45 - 450 Hz power systems. To be used with an external GFS CS series current sensor. Without CS supervision.
CS5-028	Zero sequence current sensor, 28 mm window, 500:1 ratio
CS5-050	Zero sequence current sensor, 50 mm window, 500:1 ratio
CS5-065	Zero sequence current sensor, 65 mm window, 500:1 ratio
CS5-090	Zero sequence current sensor, 90 mm window, 500:1 ratio
CS5-150	Zero sequence current sensor, 150 mm window, 500:1 ratio
CS5-240	Zero sequence current sensor, 240 mm window, 500:1 ratio
CS5-1517	Zero sequence current sensor, 150 x 170 mm window, 500:1 ratio *
CS5-1025	Zero sequence current sensor, 100 x 250 mm window, 500:1 ratio *
CS5-1035	Zero sequence current sensor, 100 x 350 mm window, 500:1 ratio *
CS5-2028	Zero sequence current sensor, 200 x 280 mm window, 500:1 ratio
CS5-3030	Zero sequence current sensor, 300 x 300 mm window, 500:1 ratio *
CS10-095	Zero sequence current sensor, 95 mm window, 1000:1 ratio
CS10-144	Zero sequence current sensor, 144 mm window, 1000:1 ratio
CS10-240	Zero sequence current sensor, 240 mm window, 1000:1 ratio
CS10-1025	Zero sequence current sensor, 100 x 250 mm window, 1000:1 ratio *
CS10-1035	Zero sequence current sensor, 100 x 350 mm window, 1000:1 ratio *
CS10-2028	Zero sequence current sensor, 200 x 280 mm window, 1000:1 ratio
CS20-095	Zero sequence current sensor, 95 mm window, 2000:1 ratio
CS20-144	Zero sequence current sensor, 144 mm window, 2000:1 ratio
CS20-240	Zero sequence current sensor, 240 mm window, 2000:1 ratio
CS20-1025	Zero sequence current sensor, 100 x 250 mm window, 2000:1 ratio *
CS20-1035	Zero sequence current sensor, 100 x 350 mm window, 2000:1 ratio *
CS20-2028	Zero sequence current sensor, 200 x 280 mm window, 2000:1 ratio
CS100-095	Zero sequence current sensor, 95 mm window, 10.000:1 ratio
CS100-144	Zero sequence current sensor, 144 mm window, 10.000:1 ratio
CS100-240	Zero sequence current sensor, 240 mm window, 10.000:1 ratio
CS100-2028	Zero sequence current sensor, 200 x 280 mm window, 10.000:1 ratio

* These current sensors are also available as a split core version, which adds /S to the name, e.g. when ordered the name is CS5-1517/S.

Note 1: all the CS5, CS10, CS20 and CS100 type Current Sensors are for use with Ground Fault Systems devices only.

Note 2: all Ground Fault Systems devices can only be used with CS series sensors.

Note 3: all CS series current sensors are protected against emitting high voltages when the secondary output is open circuit. Maximum voltage is 25 V RMS.

[Back to External Current Sensor.](#) [Back to Connections and precautions.](#) [Back to 6.1.](#)

6. TECHNICAL SPECIFICATIONS

6.1 Ground fault circuit

G/F Trip Level (settable)	30 – 100 – 500 mA and 1 – 2 – 3 – 5 - 9 A												
Accuracy of G/F trip point	-15% / +0% of Trip Level ¹												
G/F Trip Delay Time (settable)	20 - 300 ms and 1 – 2 – 5 - 10 s												
Trip Inhibit or H/C	Selectable on / off with 20 and 300 ms G/F Trip Delay Time settings.												
Accuracy of G/F Trip Delay Time	-2 / +5 ms or $\pm 2,5\%$ of Trip Delay Time, whichever is greater at > 10 times setting. See also section 6.2.												
High Current Level for 500:1 ratio CS (H/C or Trip Inhibit level)	<table border="0"> <tr> <td><u>Current wave shape</u></td> <td><u>Ext. CS</u></td> </tr> <tr> <td>Sine</td> <td>125 A AC</td> </tr> <tr> <td>IEC 60755 DC 0°</td> <td>110 A RMS</td> </tr> <tr> <td>IEC 60755 DC 90°</td> <td>80 A RMS</td> </tr> <tr> <td>IEC 60755 DC 135°</td> <td>60 A RMS</td> </tr> </table>	<u>Current wave shape</u>	<u>Ext. CS</u>	Sine	125 A AC	IEC 60755 DC 0°	110 A RMS	IEC 60755 DC 90°	80 A RMS	IEC 60755 DC 135°	60 A RMS		
<u>Current wave shape</u>	<u>Ext. CS</u>												
Sine	125 A AC												
IEC 60755 DC 0°	110 A RMS												
IEC 60755 DC 90°	80 A RMS												
IEC 60755 DC 135°	60 A RMS												
Accuracy of High Current switch point	$\pm (10 \% + 2 \text{ A})$												
Trip Inhibit Trip Delay Time	5 \pm 2 ms												
Thermal withstand capability with external CS ratio 500:1	<table border="0"> <tr> <td>300 A</td> <td>infinately</td> <td>2000 A</td> <td>125 ms</td> </tr> <tr> <td>500 A</td> <td>2000 ms</td> <td>5000 A</td> <td>20 ms</td> </tr> <tr> <td>1000 A</td> <td>500 ms</td> <td></td> <td></td> </tr> </table>	300 A	infinately	2000 A	125 ms	500 A	2000 ms	5000 A	20 ms	1000 A	500 ms		
300 A	infinately	2000 A	125 ms										
500 A	2000 ms	5000 A	20 ms										
1000 A	500 ms												
Thermal withstand capability with external CS Ratio 10.000:1	<table border="0"> <tr> <td>10.000 A</td> <td>3,00 s</td> </tr> <tr> <td>50.000 A</td> <td>1,00 s</td> </tr> <tr> <td>200.000 A</td> <td>0,05 s</td> </tr> </table>	10.000 A	3,00 s	50.000 A	1,00 s	200.000 A	0,05 s						
10.000 A	3,00 s												
50.000 A	1,00 s												
200.000 A	0,05 s												
Suitable external Current Sensor types	Different sizes with 500:1, 1000:1, 2000:1 and 10.000:1 ratio, including split rectangular sensors. See section 5.												

¹ The accuracy of the trip point refers to the value of the real world leakage current (assuming a purely sinusoidal wave shape) that just causes a trip when slowly increased from zero.

[Back to Connections and precautions.](#)

6.2 Trip Time Accuracy

The ground fault detection mechanism has a 'thermal' behaviour for greatly reduced noise sensitivity: the quoted delays are valid for sinusoidal currents exceeding the setpoint by >10 times. For reduced current excursions the delay increases as follows:

Trip current settings exceeded by a factor of:	1,2	2	4	>6
Increased Delay by:	60 ms	20 ms	8 ms	3 ms

For IEC 60755 'pulsating DC' currents, the delay increases by a further 50 ms maximum.

6.3 External Current Sensor Supervision circuit

CS loop resistance causing an open wire fault	> 1 k Ω
CS shunt resistance causing a shorted wire fault	< 50 Ω
CS Fault Trip Delay Time	1,5 s

6.4 Control Voltage

Voltage range	Nominal: 24 – 240 V AC/DC
Operating voltage tolerance:	80% to 110% of rated AC/DC voltage Total range: 19,2 - 264 V AC/DC
Frequency range on AC voltages	45 – 450 Hz
Power consumption	1,2 VA @ AC, 0,5 W @ DC
Isolation voltage	Not electrically isolated from electronics
Loss of supply tolerance (no impaired operation)	250 ms @ 24 V AC 1 s @120 V AC 4 s @230 V AC 80 ms @ 24 V DC 350 ms @ 48 V DC 750 ms @110 V DC
Power-up time	Max 500 ms for G/F detection ¹ Max 100 ms for High Current detection
Memory after loss of Control Voltage	1 week minimum (until the memory is read by pressing the reset button)

¹ If a ground fault causing a residual current above the G/F Trip Current Level but below the H/C Trip Level is already present when Control Voltage is applied, the system trips just as soon as possible, irrespective of the G/F Trip Delay time setting (rationale: the fault may be present much longer than the delay set).

6.5 System power

Voltage and current range (external CS)	Any, providing the power conductors are insulated for the system voltage.
Frequency range	45 – 450 HZ

6.6 Terminals

Type	Pull-apart
c-UL-us rating	300 V AC, 10 A
VDE rating	250 V AC, 12 A, pollution degree 3, over-voltage category III
Insulation stripping length	7 mm
Torque	0,4 – 0,6 Nm
Field wiring <i>See National Electrical Code for minimum required wire gauges.</i>	0,14 – 4,0 mm ² (VDE) 26 - 12 AWG (UL), Cu or Al, solid or stranded

6.7 Relay contacts

Configuration	Voltage free, 1 NO and 1 NC contact, 4 terminals
c-UL-us rating	5 A @ 250 V AC, general use 5 A @ 30 V DC, resistive 1/6 hp, 250 V AC 2 A, 250 VA, @ 125 V AC, pilot duty 1 A, 250 VA, @ 250 V AC, pilot duty 0,88 A, 26,4 VA, @ 30 V DC, pilot duty <u>B300:</u> 30 A, 3600 VA make, 3 A 360 VA break @ 120 V AC 15 A, 3600 VA make, 1,5 A 360 VA break @ 240 V AC
EN 60947 rating	5 A @ 250 V AC utilization category AC-12 4 A @ 250 V AC utilization category AC-13 3 A @ 250 V AC utilization category AC-14 3 A @ 250 V AC utilization category AC-15 5 A @ 30 V DC utilization category DC-12 3 A @ 24 V DC utilization category DC-13 Maximum fuse rating 13 A (EN 60947-5-1)
Isolation voltage between contacts and coil	3 kV RMS, 50 – 60 Hz, 1 minute
Breakdown voltage between open contacts	1 kV RMS
Between contact sets	2 kV RMS, 50 - 60 Hz, 1 minute

6.8 Mechanical properties (installed)

See [figure 3](#).

Height	70 mm
Width	45 mm
Depth (not including terminal block)	91 mm
Depth (including terminal block)	113 mm
DIN rail if DIN rail mounted	35 mm
Screws if screw mounted	M5 x 20 (2 needed)
Weight (open)	0,25 kg
Weight (packaged)	0,30 kg

6.9 Environment

Operating temperature	-35 °C to +60 °C
Storage temperature	-40 °C to +80 °C
Humidity	85% max (no condensation)
Ingress protection	IP20
Mechanical shock resistance (no malfunction)	10 G
Vibration resistance (no malfunction)	10 G, 10 – 55 Hz at 1,5 mm double amplitude

The DGF7-30 is encapsulated in polyurethane (PUR) to keep the exposure to mechanical shock, vibration and weather to a minimum.

7. APPLICABLE STANDARDS

EN 61000-6-3	Electromagnetic compatibility (EMC) – Part 6-3: Generic standards – Emission standard for residential (=lowest levels). 30- 230 MHz 30 dB μ V at 10 m distance 230-1000 MHz 37 dB μ V at 10 m distance
EN 61000-6-4	Electromagnetic compatibility (EMC) Part 6-4: Generic standards - Emission standard for industrial environments.
EN 61000-6-8	Electromagnetic compatibility (EMC) – Part 6-8: Generic standards – Emission standard for professional equipment in commercial and light-industrial locations.
EN 61000-6-2	Electromagnetic compatibility (EMC) – Part 6-2: Generic standards – Immunity standard for industrial environments (=highest levels) 80-1000 MHz with 80% AM modulation up to 10 V/m at 3 m distance from source.
EN 61000-4-2	Electromagnetic compatibility (EMC) - Part 4-2: Testing and measurement techniques - Electrostatic discharge immunity test.
EN 61000-4-3	Electromagnetic compatibility (EMC) - Part 4-3: Testing and measurement techniques - Radiated, radio-frequency, electromagnetic field immunity test.
EN 61000-4-4	Electromagnetic compatibility (EMC) Part 4-4: Testing and measurement techniques - Electrical fast transient/burst immunity test.
EN 61000-4-5	Electromagnetic compatibility (EMC) Part 4-5: Testing and measurement techniques - Surge immunity test.
EN 61000-4-6	Electromagnetic compatibility (EMC) Part 4-6: Testing and measurement techniques - Immunity to conducted disturbances, induced by radio-frequency fields.
EN 61000-4-11	Electromagnetic compatibility (EMC) Part 4-11: Testing and measurement techniques - Voltage dips, short interruptions and voltage variations immunity tests for equipment with input current up to 16 A per phase.
EN 60947-5-1	Low-voltage switchgear and controlgear – Part 5-1: Control circuit devices and switching elements – Electromechanical control circuit devices.
IEC 60755	General requirements for residual current operated protective devices
c-UL-us	UL 1053 UL standard for Safety Ground-Fault Sensing and Relaying Equipment, Class 1. CSA C22.2 NO. 144-M1991 CSA standard for Ground Fault Circuit Interrupters. File E203514
CE	CE mark – Declaration of Conformity

8. TABLES AND FIGURES

8.1 Table 1 - Dipswitch settings

'R' denotes right and 'L' denotes left.

Values are primary currents for a 500:1 ratio external Current Sensor. For other ratios see [Table 2](#).

Switch no.	Parameter	Set to	Meaning
1 2 3	Ground Fault Trip level	L L L ♦ L L R L R L L R R R L L R L R R R L R R R	0,030 A 0,100 A 0,500 A 1,00 A 2,00 A 3,00 A 5,00 A 9,00 A
4 5 6	Ground Fault Trip Delay time and Trip Inhibit	L L L ♦ L L R L R L L R R R L L R L R R R L R R R	20 ms without Trip Inhibit 20 ms with Trip Inhibit 300 ms without Trip Inhibit 300 ms with Trip Inhibit 1 s without Trip Inhibit 2 s without Trip Inhibit 5 s without Trip Inhibit 10 s without Trip Inhibit
7 8	Operating Mode	L L ♦ L R R L R R	Continuous Non-Failsafe operation Continuous Failsafe operation Pulsed Non-Failsafe operation Pulsed Failsafe operation
♦ Factory settings			

To discourage unauthorized manipulation, settings can only be changed by going through a procedure. See [section 2.1.4 Tamper proof dipswitches](#)

[Back to Dipswitch settings.](#)

[Back to Operating Modes.](#)

8.2 Table 2 - Primary current Trip level and High Current level

Values are primary currents.

DGF7-30 Setting	External current sensor ratio's			
	500:1	1000:1	2000:1	10.000:1
0,030 A	0,030 A	0,060 A	0,120 A	0,60 A
0,100 A	0,100 A	0,200 A	0,400 A	2,00 A
0,500 A	0,500 A	1,00 A	2,00 A	10,0 A
1,00 A	1,00 A	2,00 A	4,00 A	20,0 A
2,00 A	2,00 A	4,00 A	8,00 A	40,0 A
3,00 A	3,00 A	6,00 A	12,00 A	60,0 A
5,00 A	5,00 A	10,0 A	20,0 A	100,0 A
9,00 A	9,00 A	18,0 A	36,0 A	180,0 A
H/C level	125 A	250 A	1000 A	2500 A

[Back to General Description.](#)

[Back to External Current Sensor.](#)

[Back to Table 1.](#)

8.3 Figure 1 - Typical field connection with a shunt trip device and external Current Sensor

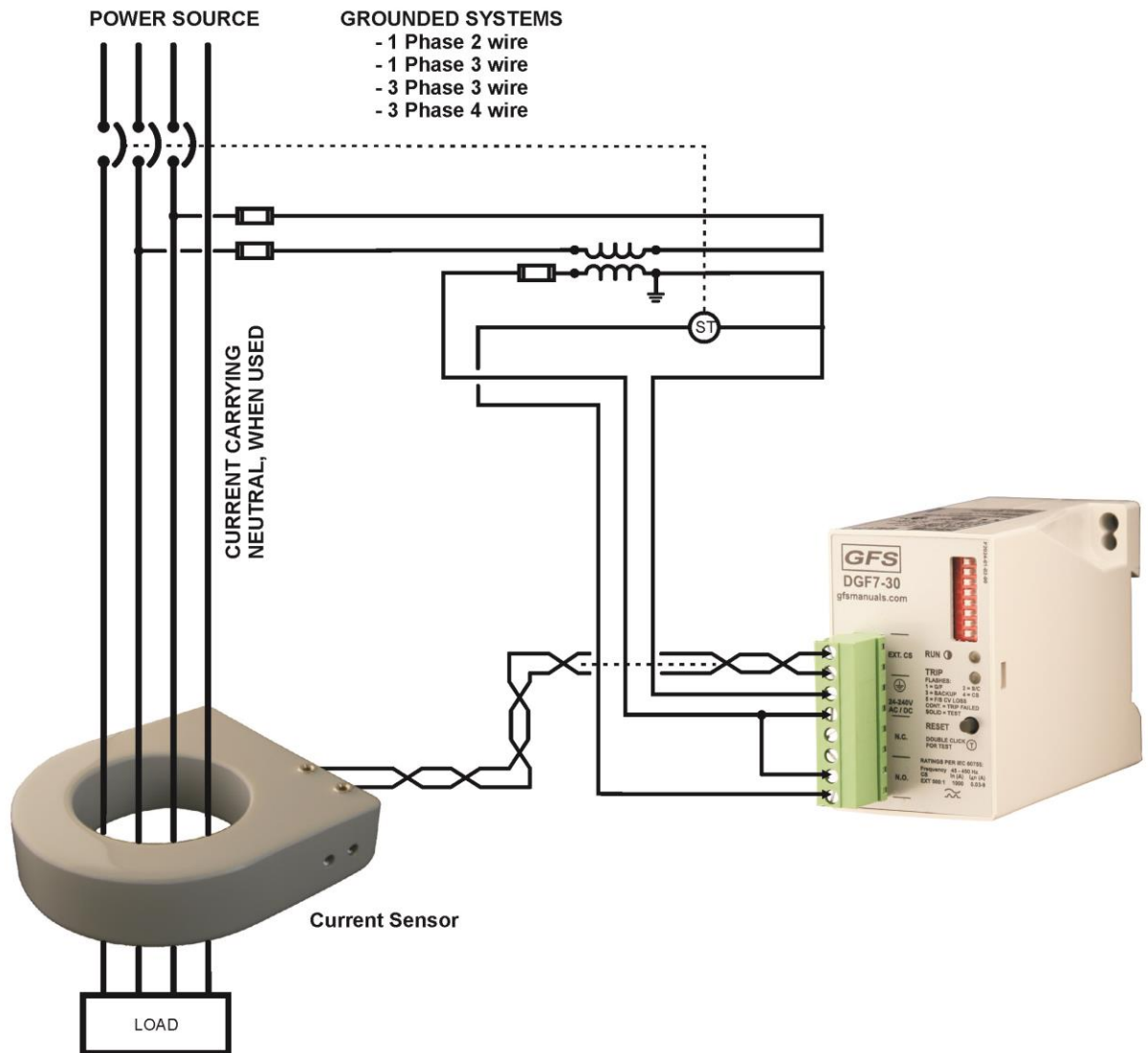

8.4 Figure 2 - Typical field connection with a start-stop device and external Current Sensor

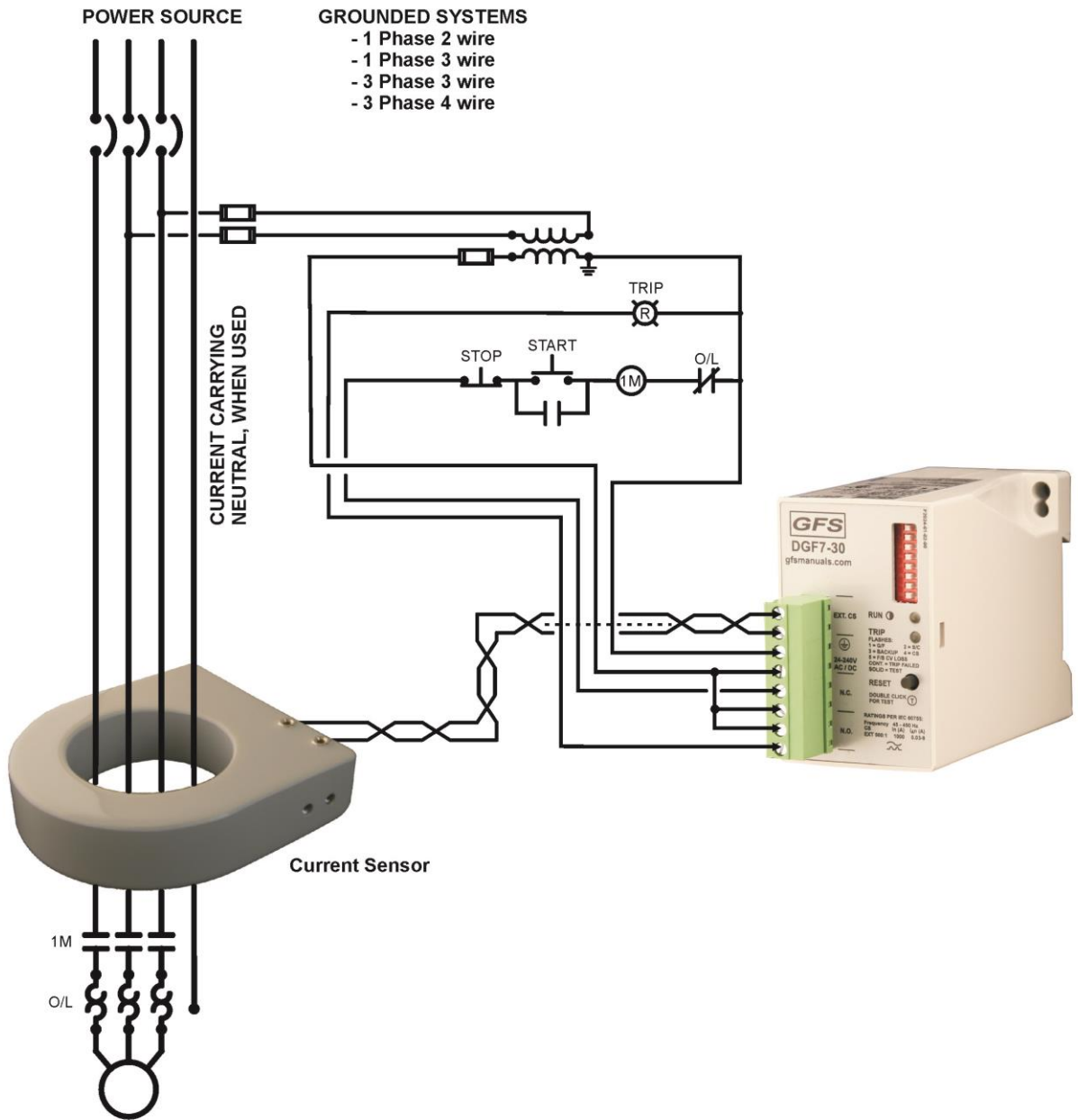

8.5 Figure 3 - Dimensions DGF7-30

